

REV-A-SHELF®

INSTALLATION INSTRUCTIONS

53WC SERIES PULLOUT WASTE CONTAINER

TOOLS REQUIRED:

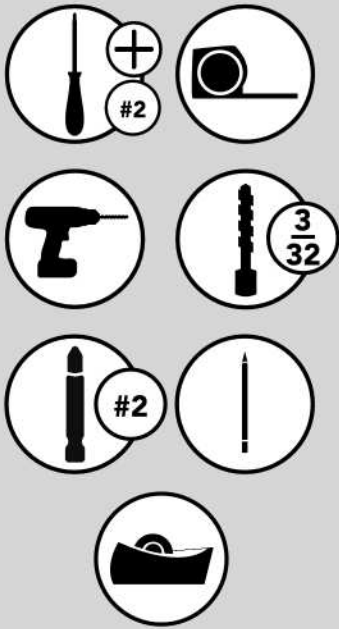

ESTIMATED ASSEMBLY TIME:

30 MIN

CARE AND MAINTENANCE:

Clean with a damp cloth and wipe parts dry.



Parts List		
No.	Description	Qty
1	Slides	2
2	Chassis Bottom	1
3	Waste Container	1 or 2
4	Door Mount Bracket	2
5	Wall Sides	2
6	Rear Basket (Single Version Only)	1
7	Connecting Rod	1
8	#8 x 3/4" Deep Thread Screws	8
9	#8 x 1/2" Pan Head Screws	2
10	M4 x 10mm Flat Head Screws	4
11	#6 x 1/2" Flat Head Screws	6
12	1/4-20 x 5/8" Phillips Bolt (w/ Washer)	4
13	1/4-20 x 1 1/4" Phillips Bolt (w/ Washer)	4
14	Connecting Rod Arm	2
15	Spacer	8

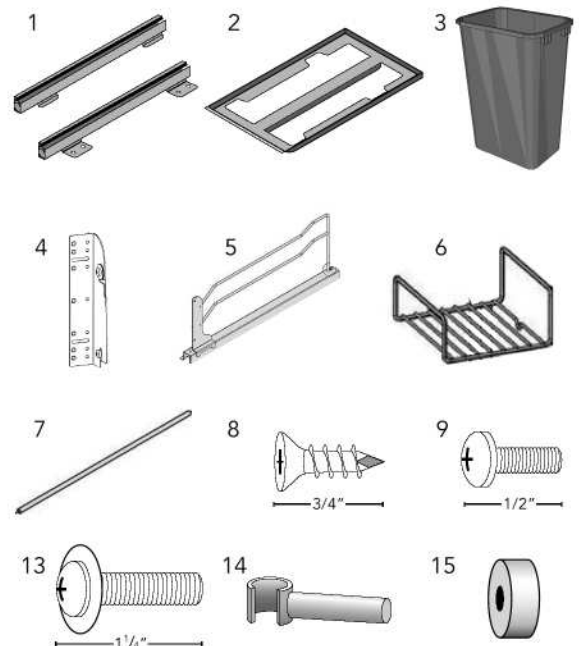

STEP 1

Install the wall sides to the slides as shown in figure 1. Be sure to securely engage the rear of the slide under the metal tab before installing the phillips head screws at the front of the slides. Be sure the slide feet are pointed inward as shown.



FIGURE 1

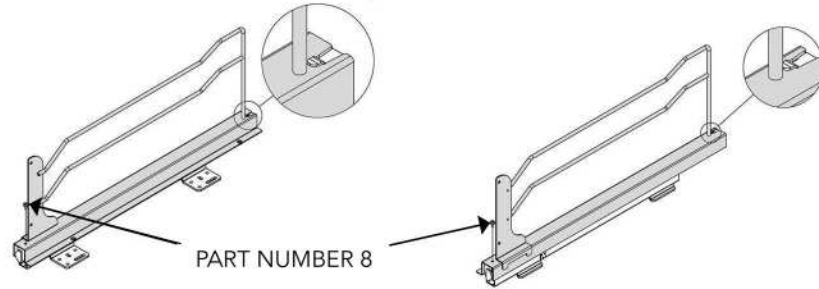

STEP 2

Install the main chassis to the slides as shown using the 4 machine screws provided. Install the connecting rod at this time.



FIGURE 2

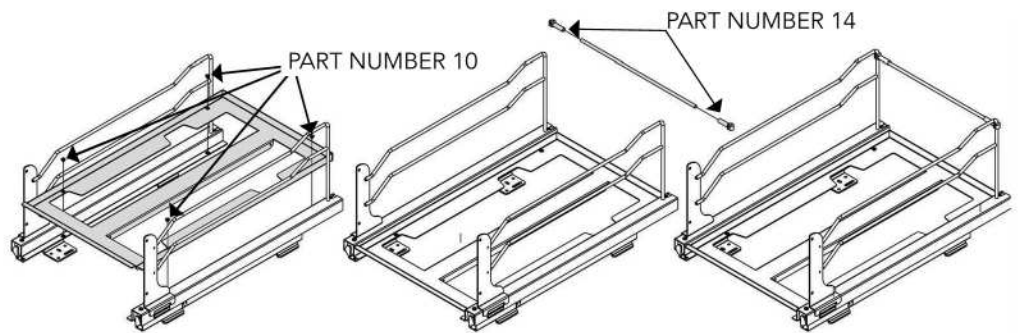

STEP 3

Using the template provided, mount the waste container frame to the cabinet floor. NOTE: If installing in an inset application, the template must be moved back the thickness of the door.



FIGURE 3

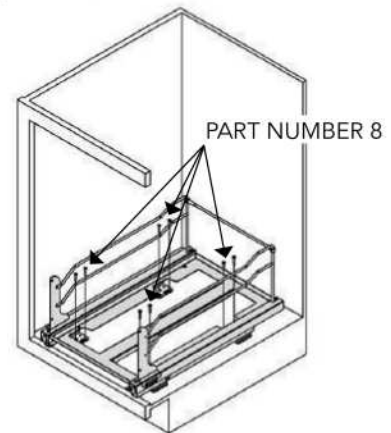
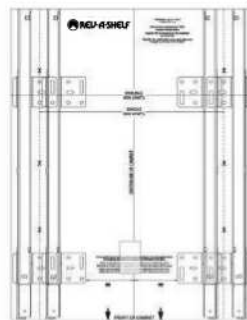

STEP 4A

Attach the door brackets to the outside of the L-brackets using the (4) provided 5/8" bolts (part number 11). The screw with the washer goes at the top.

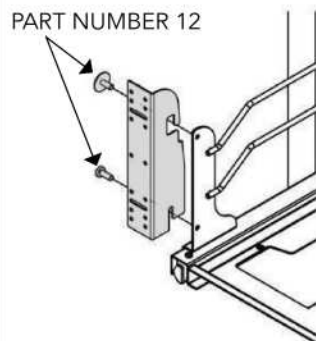
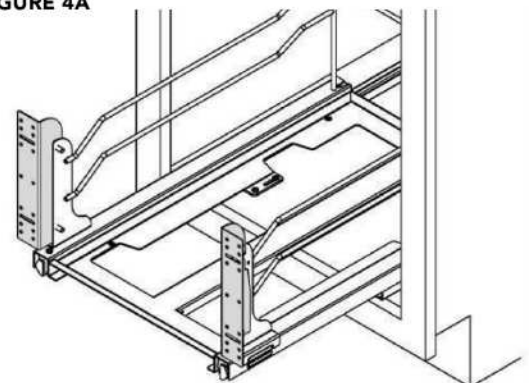

FIGURE 4A



STEP 4B

Each cabinet door is different, so make sure the door brackets line up with the thick portion of the cabinet door (See Figure 4B). This will ensure that the screws will not go completely through the door. NOTE: Plastic spacers are provided if the door brackets need to be extended further to reach the thick portion of the door (See Figure 4C). If so, you will need to replace the 5/8" bolts (part number 12) with the 1 1/4" bolts (part number 13).



FIGURE 4B

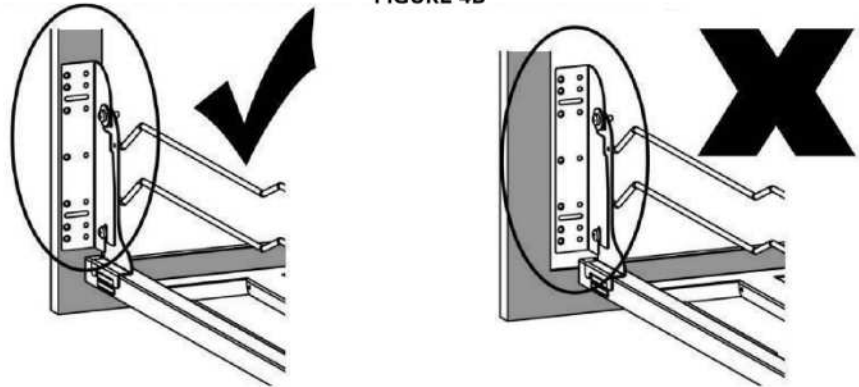
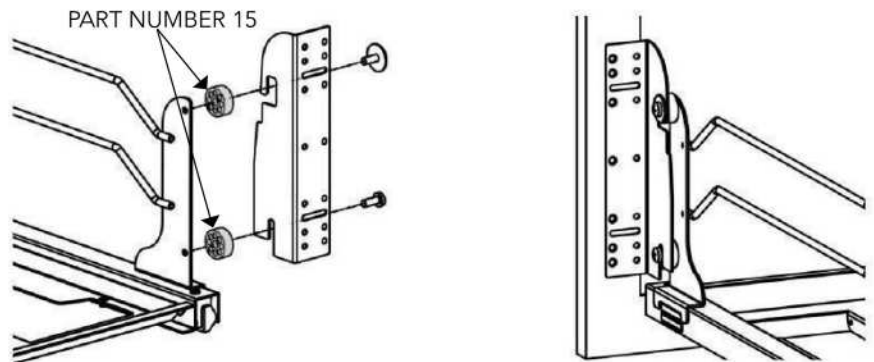

FIGURE 4C



STEP 5A

Refer to Figure 5A to determine door mounting hole locations. Transfer these dimensions to your door from the bottom and the hole locations. Pre-drill these holes on the back side of your cabinet door, making sure not to drill through the door.

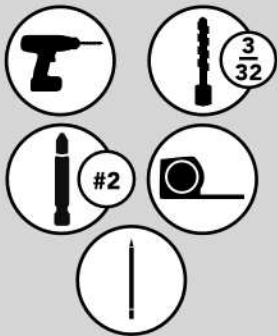
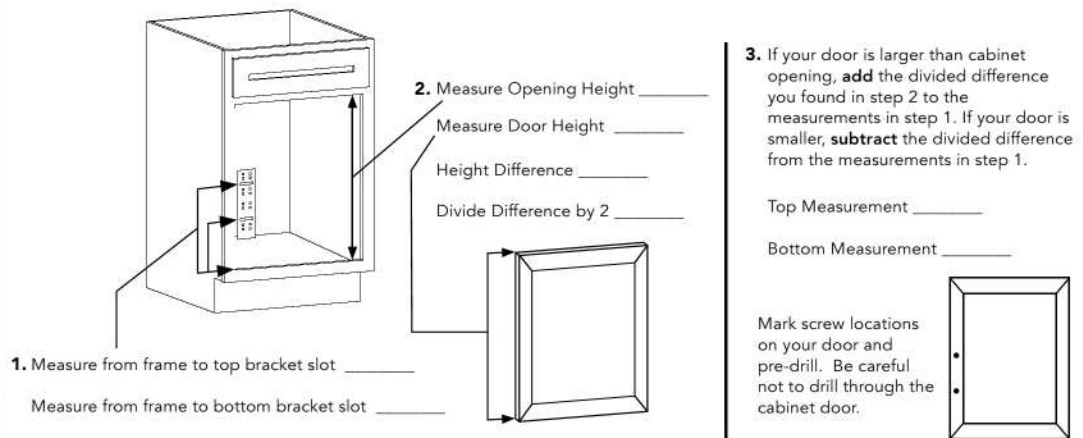

FIGURE 5A



**STEP 5B
ALTERNATE METHOD**

Apply double stick tape to the door brackets. Attach cabinet door to the brackets while trying to keep door level. Don't worry if it is off a little. This can all be adjusted. Double stick tape will hold the door in place while you screw the brackets to cabinet door. (See Figure 5B)

NOTE: Although this method is the quickest and easiest method to attach the door, it does limit adjustability since the door will become adhered to the brackets

FIGURE 5B

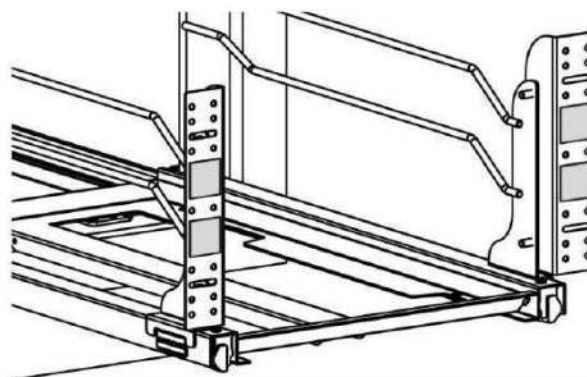

STEP 6

Using provided flat head wood screws, secure brackets to cabinet door. (See Figure 6)

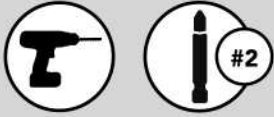
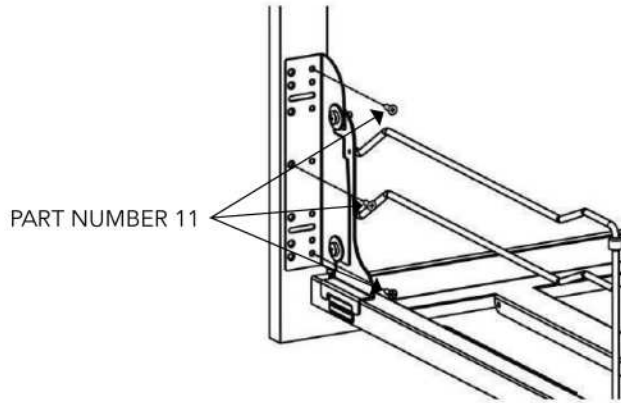

FIGURE 6



STEP 7

Now that the cabinet door is attached, you will be able to fully adjust the door by loosening and positioning the bolts on the side of the door mount bracket (See Figure 7). Once the door is aligned correctly, retighten the 2 bolts on each side.



FIGURE 7

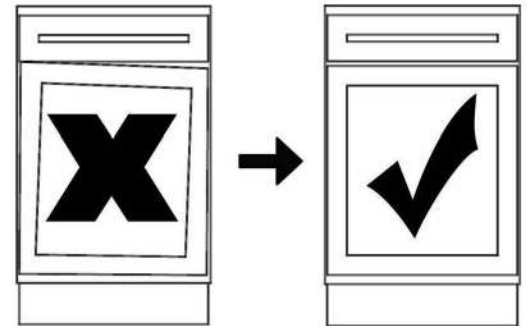
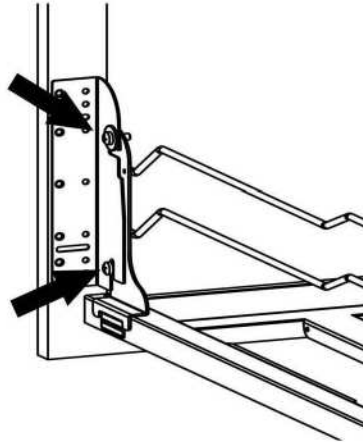

FIGURE 8

STEP 8

Your waste container(s) are now ready to be installed. On the single bin units, a rear basket is provided for extra storage. (See Figure 8)

