



Features

- ◆ **Lighting:** 9.5 Watt Flood LED
- ◆ **Filters:** Slim Baffle
- ◆ **Rails:** Decorative Rails available.
- ◆ **Optional Duct Cover:** Made to your specification.

Specifications

- ◆ **Power:** Air Ring Fan 390 CFM.
- ◆ **Stainless:** Complete Marine Grade 304 Stainless steel construction for Durability and Fire Safety.
- ◆ **Finishes:** Standard: Stainless Steel, White or black powder coat available.
- ◆ **Distance Codes:** Check local city, county and cooking appliance specifications. Recommended 30” to 36” above cooking surface.
- ◆ **Installation:** Under cabinet or wall mount for easy installation.

Warranty

- ◆ Warranty: 7 Year, In-Home—Parts & Labor. (Best in the Industry!)
- ◆ No “Performance” Warranty when used above BBQ Style Grills.

MODELS	POWER CFM	MOTOR TYPE	CONTROLS	SONES LOW-HI	DEPTH	DUCT	SIZES
WH1900SD4SB	390	Air Ring Fan	Variable	2.5 - 7.6	24”	Single 7”	30”, 36”, 42”, 48”

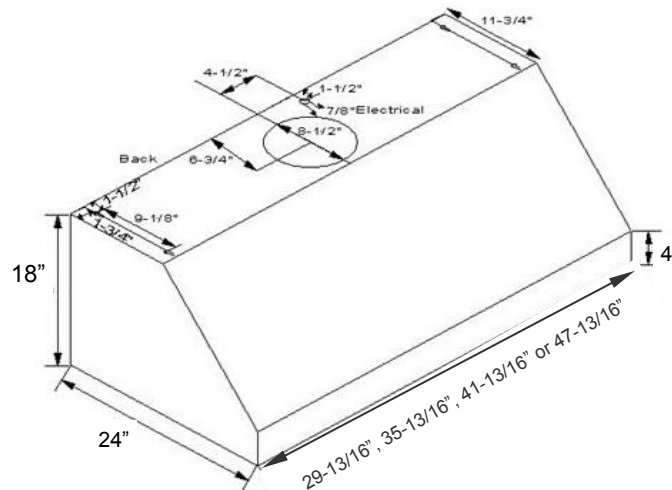

ICP does not guarantee the performance warranty over all cooking surfaces due to the variation of BTU output and cooking surfaces. The unit is designed to meet the International Builder Codes 400 CFM without make-up air required.