

INSTALLATION INSTRUCTIONS for Wells Undermount Stainless Steel Sinks

1. Wells Sinkware undermount stainless steel sinks can be installed in three different ways in terms of the width of the deck of a sink that reveals under the countertop:
 - a. Flush mount: the edge of countertop opening meets the edge of sink rim on all sides;
 - b. Overhang: counter top extends about 1/8" over the sink rim on all sides;
 - c. Positive reveal: sink rim extends about 1/8" to 3/16" from the edge of countertop opening on all sides.

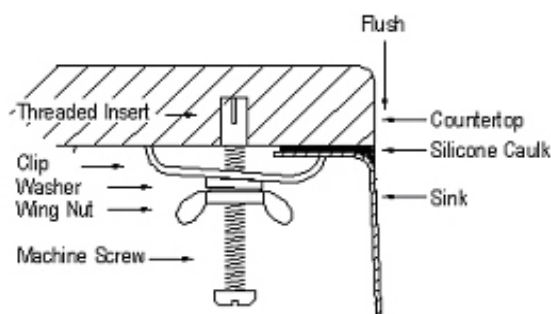

Illustration 1: Flush

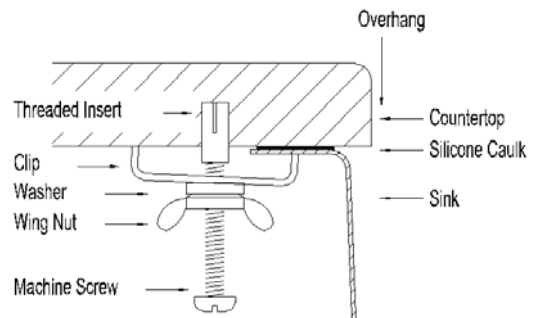

Illustration 2: Overhang

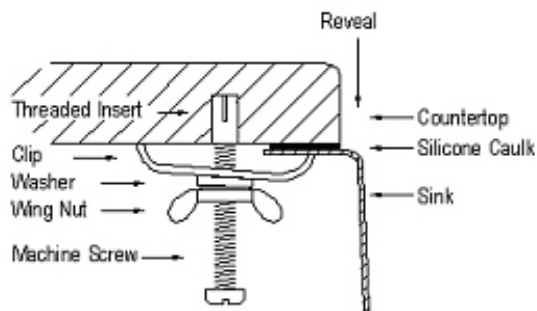

Illustration 3: Reveal

The template accompanying the sink is for 3/16" positive reveal installation for all Chicago Series and 2-in-1 (1/4" positive reveal and flush mount) for all other series (Oriental Myth, Naperville and Jazz). If you want the sink

installed differently from what the template offers, make sure to tell your fabricator your preference.

2. Position template at desired location on the countertop allowing necessary space for sink to fit into cabinet, and enough room on the countertop for drilling holes for clips (underside of countertop), faucet, and soap dispenser, etc.
3. On the underside of the countertop, about $\frac{3}{4}$ " or closer depending on the space available from the edge of sink flange, mark spots for threaded inserts (not provided), or other mounting methods a professional fabricator/installer may use, at flange corners and every 6" to 7" apart around the sink flange.
4. Drill holes (size of which is determined according to the size of screws, wing nuts, washers and threaded inserts you use) at marked locations. Tap in threaded inserts with slotted end first.
5. Clean sink flange and the countertop surface where sink flange will be mounted with a solvent such as denatured alcohol. Dry thoroughly and apply a thin bead of clear silicone caulk around the top deck of sink flange.
6. Position and align sink over the countertop opening and press sink against countertop.
7. Assemble mounting hardware, as illustrated in Illustration 1 and 2, and thread screws into threaded inserts. Tighten wing nuts lightly until mounting clips are against flange of sink.
8. Adjust the position of sink if necessary. Make sure it is aligned to the cutout opening. Completely tighten all wing nuts. Remove excess silicone caulk around the inside and outside edges of sink flange. After silicon cures, wipe inside edge with denatured alcohol. This will smooth out any rough areas.

Notes:

1. WELLS recommends that Wells Sinkware under-mount sinks be installed by professional countertop fabricators/installers.
2. The template is only a guide. It's important that you check the template provided with your sink against the sink (to assure that template agrees with sink) before cutting the counter top.