

Granville MEDICINE CABINET

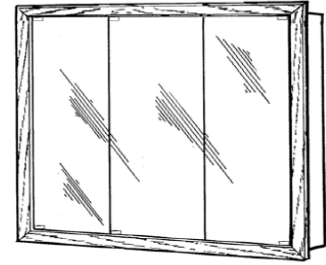

FEATURES/TYPICAL SPECIFICATIONS

- Surface-Mounted Installation
 - Two Integral Mounting Bars
 - Pre-Drilled Mounting Holes (4 typical)
- Housing/Body is Panel Style Construction (WD)
 - Particle Board Construction with PVC Laminate
 - MDF Back Panel with Honey Oak PVC Laminate on interior cabinet surface
 - Dowel/Glue & Tongue & Groove Construction
- Solid Wood Frame with Miter Cut Corners
 - Solid Oak with Honey Oak Finish (OK01)
 - The frame is attached to the top, bottom, and side panels of housing by glue and tongue in groove or glue and wooden dowels as a minimum.
- Mirror Doors (3 typical)
 - Right-hand swing (2 typical) and left-hand swing (1 typical)
 - Polished Edges, 4 sides
 - Laminated Protective Mirror Backing
- Shelves, particle board with honey oak PVC laminate (2 typical)
 - Fixed, non-removable (FX)
- Chrome Finish Glass Pivot Hinges, set of two (3 sets typical) (HG03)
- Spring-loaded, espresso magnetic touch latch fastened to cabinet body aligns to chrome finished metal plate on the mirror door back (3 typical)
- Includes Mounting Hardware

Finishes:

Housing: OK01-Honey Oak
 Mirror: POL1-Polished Edge
 Frame: OK01-Honey Oak

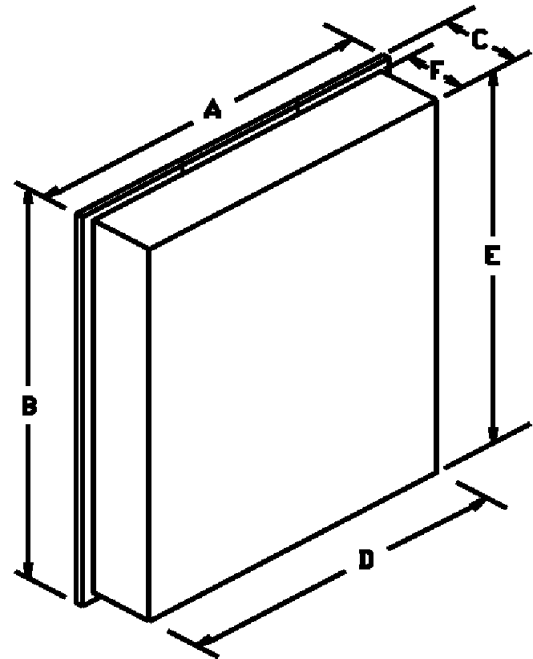

CARB 93120 Phase 2 Compliant for Formaldehyde

		Dimensions In Inches					
Model #	Description	A	B	C	D	E	F
740647	MEDCAB 3DR 36X30 FMLS WD	36	30	4 $\frac{3}{4}$	34 $\frac{3}{8}$	28-3/16	4

REFERENCE	QTY.	REMARKS	Project
			Location
			Architect
			Engineer
			Contractor
			Submitted by
			Date

* All models and material specifications are subject to change or withdrawal without notice.