



ITEM #: \_\_\_\_\_ QTY: \_\_\_\_\_  
 MODEL #: \_\_\_\_\_  
 PROJECT NAME: \_\_\_\_\_

071917

**∴kitchensource.com**  
 1.800.667.8721

**"ST4R5-GSK" STAINLESS STEEL TOP WORK TABLES**  
**14GA TOP W/ 5" RISER AND GALV LEGS AND ADJUSTABLE UNDERSHELF**



**FEATURES:**

- 14 GAUGE STAINLESS STEEL TOP W/ 5" RISER & TURNDOWN
- TYPE 300 STAINLESS STEEL WITH # 4 POLISH, SATIN FINISH
- TOP IS SOUND DEADENED
- REINFORCED WITH 1"X2" CHANNEL RUNNING ENTIRE LENGTH OF TABLE
- 1-1/2" STALLION EDGE ON FRONT SIDE EDGES  
90 DEGREE BEND DOWN FOR TABLE LINE-UP
- GALVANIZED BASE WITH ADJUSTABLE UNDERSHELF
- SHIPPED KNOCKED-DOWN, EASY-TO-ASSEMBLE
- NSF CERTIFIED



ST4R5-3048GSK

**CONSTRUCTION:**

- TOP: STAINLESS STEEL TOPS ARE TIG WELDED, EXPOSED WELDS ARE POLISHED TO MATCH ADJACENT SURFACE.

**MATERIAL:**

- TOP: 14 GAUGE STAINLESS STEEL TYPE 300 STAINLESS STEEL WITH # 4 POLISH, SATIN FINISH
- SHELF: 18 GAUGE GALVANIZED STEEL, (36" WIDE TABLES, 16 GAUGE LOWER SHELF)
- LEGS: 1-5/8" ROUND O.D. 16 GAUGE TUBULAR GALVANIZED STEEL
- GUSSETS: GALVANIZED STEEL
- FEET: 1" GALVANIZED BULLET FEET



ADJUSTABLE SHELF

**14 GAUGE TOP W/ ADJUSTABLE SHELF**

24" WIDE	QTY	30" WIDE	QTY	36" WIDE	QTY
ST4R5-2424GSK		ST4R5-3024GSK		ST4R5-3624GSK	
ST4R5-2430GSK		ST4R5-3030GSK		ST4R5-3630GSK	
ST4R5-2436GSK		ST4R5-3036GSK		ST4R5-3636GSK	
ST4R5-2448GSK		ST4R5-3048GSK		ST4R5-3648GSK	
ST4R5-2460GSK		ST4R5-3060GSK		ST4R5-3660GSK	
ST4R5-2472GSK		ST4R5-3072GSK		ST4R5-3672GSK	
ST4R5-2484GSK		ST4R5-3084GSK		ST4R5-3684GSK	
ST4R5-2496GSK		ST4R5-3096GSK		ST4R5-3696GSK	
ST4R5-24108GSK		ST4R5-30108GSK		ST4R5-36108GSK	
ST4R5-24120GSK		ST4R5-30120GSK		ST4R5-36120GSK	
ST4R5-24132GSK		ST4R5-30132GSK		ST4R5-36132GSK	
ST4R5-24144GSK		ST4R5-30144GSK		ST4R5-36144GSK	

**OPTIONAL ACCESSORIES**

DESCRIPTION	MODEL #	QTY
DRAWER		
DRAWER LOCK		
CASTERS		
OVERSHELVES		
SINKS		
POT RACK		

# DETAILED SPECIFICATIONS

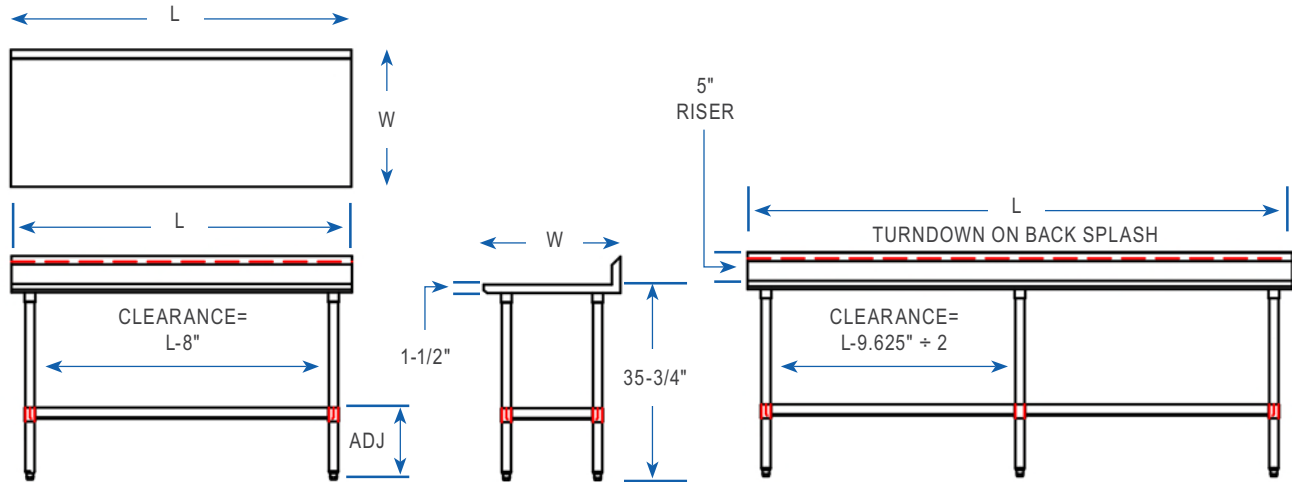

- UNITS 7 FT. AND LARGER ARE FURNISHED WITH SIX LEGS.
- FINISHED SIZE OF UNDERSHELF.  
SHELF LENGTH = LENGTH MINUS 4.875"  
SHELF WIDTH = WIDTH MINUS 4.25

### 14 GAUGE TOP W/ ADJUSTABLE UNDERSHELF

LENGTH	24" WIDE	WT. (LBS)	30" WIDE	WT. (LBS)	36" WIDE	WT. (LBS)
24"	ST4R5-2424GSK	45	ST4R5-3024GSK	54	ST4R5-3624GSK	60
30"	ST4R5-2430GSK	54	ST4R5-3030GSK	61	ST4R5-3630GSK	73
36"	ST4R5-2436GSK	61	ST4R5-3036GSK	69	ST4R5-3636GSK	84
48"	ST4R5-2448GSK	75	ST4R5-3048GSK	86	ST4R5-3648GSK	104
60"	ST4R5-2460GSK	89	ST4R5-3060GSK	103	ST4R5-3660GSK	124
72"	ST4R5-2472GSK	104	ST4R5-3072GSK	119	ST4R5-3672GSK	145
84"	ST4R5-2484GSK	125	ST4R5-3084GSK	143	ST4R5-3684GSK	176
96"	ST4R5-2496GSK	139	ST4R5-3096GSK	160	ST4R5-3696GSK	197
108"	ST4R5-24108GSK	153	ST4R5-30108GSK	176	ST4R5-36108GSK	217
120"	ST4R5-24120GSK	166	ST4R5-30120GSK	193	ST4R5-36120GSK	238
132"	ST4R5-24132GSK	180	ST4R5-30132GSK	209	ST4R5-36132GSK	258
144"	ST4R5-24144GSK	194	ST4R5-30144GSK	226	ST4R5-36144GSK	278

## MODEL # STRUCTURE

24 = WIDTH OF WORK SURFACE  
 5 = HT. OF RISER W/ TURNDOWN  
 R = RISER TOP WORK TABLE  
 4 = 14GA WORK SURFACE  
 ST = STAINLESS STEEL TOP

30 = LENGTH OF WORK SURFACE  
 GS = GALVANIZED LEGS & SHELF  
 K = K.D. W/ ADJUSTABLE BRACING

**ST4R5-2430GSK**

SOME UNITS SHIP UNASSEMBLED FOR REDUCED SHIPPING COST. ALL DIMENSIONS ARE TYPICAL. TOLERANCE +/- .500"

John Boos & Co. is constantly engaged in a program of improving products and therefore reserves the right to change specifications without prior notice.

