



"TNB" Maple Top Work Tables

w/ 2 1/4" thick Hard Rock Maple Top
w/ Stainless Steel Base



AUTOQUOTES



2 1/4" MAPLE TOP w/
STAINLESS STEEL BASE

FEATURES:

- * 2 1/4" Thick Hard Rock Maple Top top style "BKSC" flat top
- * Maple top is finished with penetrating oil with optional natural clear Varnique Finish
- * Stainless Steel Base and Bracing Type 300 stainless steel with # 4 polish, satin finish
- * Bracing adjustable to desired height
- * Adjustable bullet feet
- * Shipped knocked-down, easy - to - assemble
- * Optional drawers, casters, pot racks, etc. available
- * All models are approved by the National Sanitation Foundation

MATERIAL:

- Top: Laminated Hard Rock Maple
- Bracing: 1 1/4" Round O.D. 18 gauge type 300 tubular stainless steel # 4 polish, satin finish
- Legs: 1 5/8" Round O.D., 16 gauge type 300 tubular stainless steel # 4 polish, satin finish
- Gussets: Stainless Steel
- Feet: 1" adjustable stainless steel bullet feet

OPTIONAL ACCESSORIES

	MODEL #	Qty
STAINLESS STEEL FEET		
DRAWER		
DRAWER LOCK		
CASTERS		
OVERSHELVES		
POT RACK		

DETAILED SPECIFICATIONS

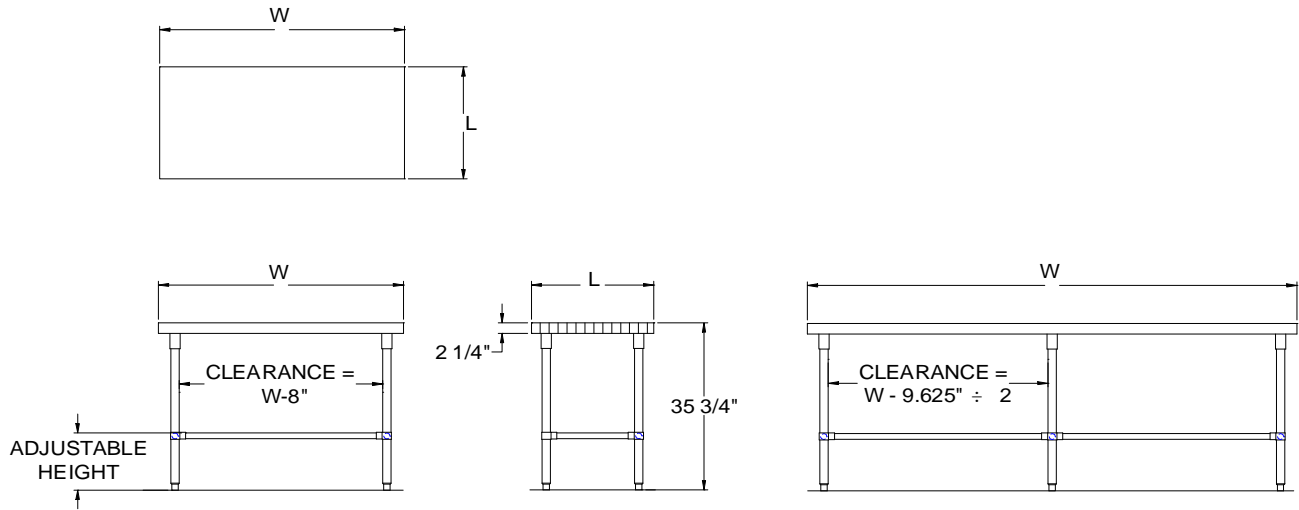

All units ship unassembled for reduced shipping cost.
Units 7 ft. and larger are furnished with six legs.
All dimensions are typical.
Tolerance +/- .500".

Finished size of undershelf.
Shelf length = length minus 4.25"
Shelf width = width minus 4.875"

2 1/4" MAPLE TOP & STAINLESS STEEL BASE

W	24" L	WT.	30" L	WT.	36" L	WT.
36	TNB01	77	TNB07	93	TNB13	106
48	TNB02	96	TNB08	115	TNB14	134
60	TNB03	115	TNB09	140	TNB15	166
72	TNB04	134	TNB10	167	TNB16	191
84	TNB04A	158	TNB10A	193	TNB16A	224
96	TNB05	182	TNB11	219	TNB17	257
108	TNB05A	201	TNB11A	243	TNB17A	285
120	TNB06	220	TNB12	267	TNB18	313



July 2013

John Boos is constantly engaged in a program of improving products and therefore reserves the right to change specification without prior notice