



ITEM #: _____ QTY: _____
 MODEL #: _____
 PROJECT NAME: _____

071917

∴kitchensource.com
 ☎ 1.800.667.8721

"ST6-SSK" STAINLESS STEEL TOP WORK TABLES
16GA TOP AND STAINLESS STEEL LEGS AND ADJUSTABLE UNDERSHELF



FEATURES:

- 16 GAUGE STAINLESS STEEL TOP
- TYPE 300 STAINLESS STEEL WITH # 4 POLISH, SATIN FINISH
- TOP IS SOUND DEADENED
- REINFORCED WITH 1"X2" CHANNEL RUNNING ENTIRE LENGTH OF TABLE
- 1-1/2" STALLION EDGE ON FRONT AND REAR WITH SIDE EDGES 90 DEGREE BEND DOWN FOR TABLE LINE-UP
- STAINLESS BASE WITH ADJUSTABLE UNDERSHELF
- ADJUSTABLE BULLET FEET
- SHIPPED KNOCKED-DOWN, EASY-TO-ASSEMBLE
- NSF AND CSA CERTIFIED



ST6-3048SSK

CONSTRUCTION:

- TOP: STAINLESS STEEL TOPS ARE TIG WELDED, EXPOSED WELDS ARE POLISHED TO MATCH ADJACENT SURFACE.

MATERIAL:

- TOP: 16 GAUGE STAINLESS STEEL TYPE 300 STAINLESS STEEL WITH # 4 POLISH, SATIN FINISH
- SHELF: 18 GAUGE STAINLESS STEEL, (36" WIDE TABLES, 16 GAUGE LOWER SHELF)
- LEGS: 1-5/8" ROUND O.D., 16 GAUGE TUBULAR STAINLESS STEEL
- GUSSETS: STAINLESS STEEL
- FEET: 1" ADJUSTABLE STAINLESS BULLET FEET



ADJUSTABLE SHELF

16 GAUGE TOP W/ ADJUSTABLE SHELF

24" WIDE	QTY	30" WIDE	QTY	36" WIDE	QTY
ST6-2424SSK		ST6-3024SSK		ST6-3624SSK	
ST6-2430SSK		ST6-3030SSK		ST6-3630SSK	
ST6-2436SSK		ST6-3036SSK		ST6-3636SSK	
ST6-2448SSK		ST6-3048SSK		ST6-3648SSK	
ST6-2460SSK		ST6-3060SSK		ST6-3660SSK	
ST6-2472SSK		ST6-3072SSK		ST6-3672SSK	
ST6-2484SSK		ST6-3084SSK		ST6-3684SSK	
ST6-2496SSK		ST6-3096SSK		ST6-3696SSK	
ST6-24108SSK		ST6-30108SSK		ST6-36108SSK	
ST6-24120SSK		ST6-30120SSK		ST6-36120SSK	
ST6-24132SSK		ST6-30132SSK		ST6-36132SSK	
ST6-24144SSK		ST6-30144SSK		ST6-36144SSK	

OPTIONAL ACCESSORIES

DESCRIPTION	MODEL #	QTY
DRAWER		
DRAWER LOCK		
CASTERS		
OVERSHELVES		
SINKS		
POT RACK		

DETAILED SPECIFICATIONS

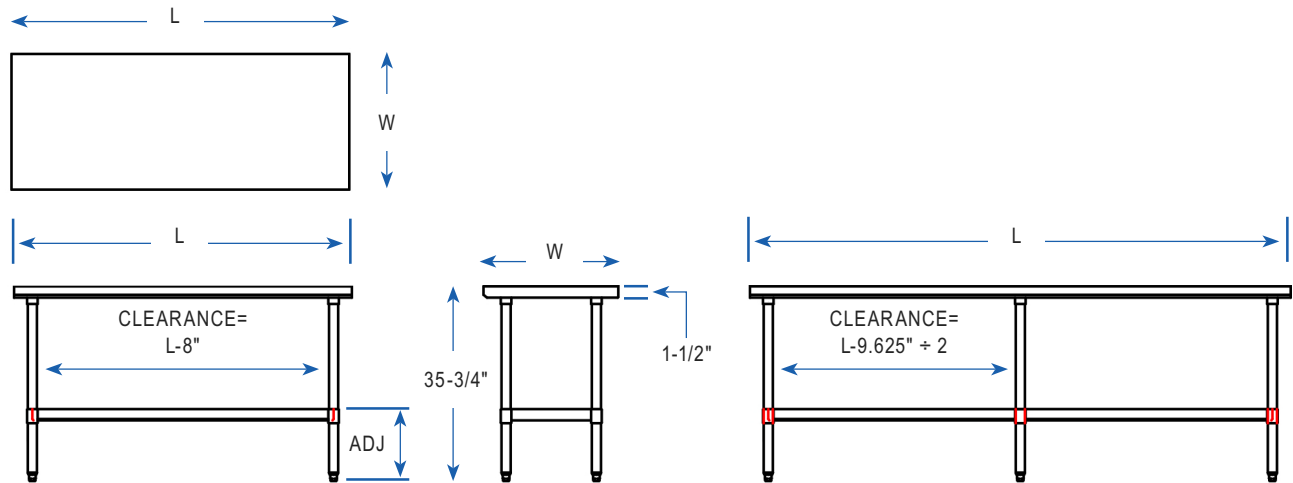

- UNITS 7 FT. AND LARGER ARE FURNISHED WITH SIX LEGS.
- FINISHED SIZE OF UNDERSHELF.
SHELF LENGTH = LENGTH MINUS 4.875"
SHELF WIDTH = WIDTH MINUS 4.25

16 GAUGE TOP W/ ADJUSTABLE SHELF

LENGTH	24" WIDE	WT. (LBS)	30" WIDE	WT. (LBS)	36" WIDE	WT. (LBS)
24"	ST6-2424SSK	36	ST6-3024SSK	44	ST6-3624SSK	50
30"	ST6-2430SSK	44	ST6-3030SSK	50	ST6-3630SSK	59
36"	ST6-2436SSK	79	ST6-3036SSK	59	ST6-3636SSK	75
48"	ST6-2448SSK	64	ST6-3048SSK	82	ST6-3648SSK	82
60"	ST6-2460SSK	76	ST6-3060SSK	85	ST6-3660SSK	109
72"	ST6-2472SSK	91	ST6-3072SSK	101	ST6-3672SSK	130
84"	ST6-2484SSK	104	ST6-3084SSK	120	ST6-3684SSK	138
96"	ST6-2496SSK	118	ST6-3096SSK	137	ST6-3696SSK	265
108"	ST6-24108SSK	134	ST6-30108SSK	154	ST6-36108SSK	171
120"	ST6-24120SSK	142	ST6-30120SSK	166	ST6-36120SSK	187
132"	ST6-24132SSK	157	ST6-30132SSK	155	ST6-36132SSK	185
144"	ST6-24144SSK	172	ST6-30144SSK	198	ST6-36144SSK	240

MODEL # STRUCTURE

24 = WIDTH OF WORK SURFACE
6 = 16GA WORK SURFACE
ST = STAINLESS STEEL TOP

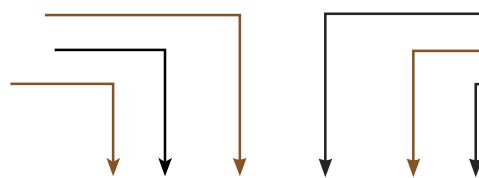

30 = LENGTH OF WORK SURFACE
SS = STAINLESS LEGS & SHELF
K = K.D. W/ ADJUSTABLE BRACING

ST6-2430SSK

SOME UNITS SHIP UNASSEMBLED FOR REDUCED SHIPPING COST. ALL DIMENSIONS ARE TYPICAL. TOLERANCE +/- .500"

John Boos & Co. is constantly engaged in a program of improving products and therefore reserves the right to change specifications without prior notice.