

EDGE DETAIL
DRAWER FRONT

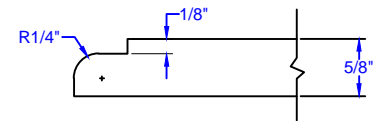
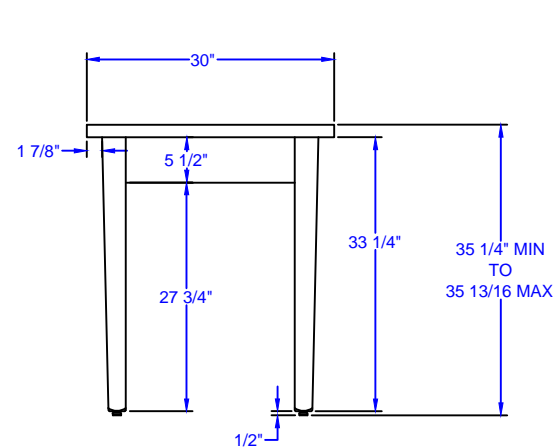

MATERIALS

DECK: 16GA SS

BASE: HM