

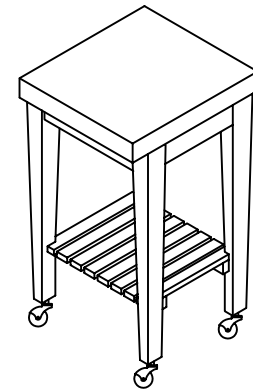

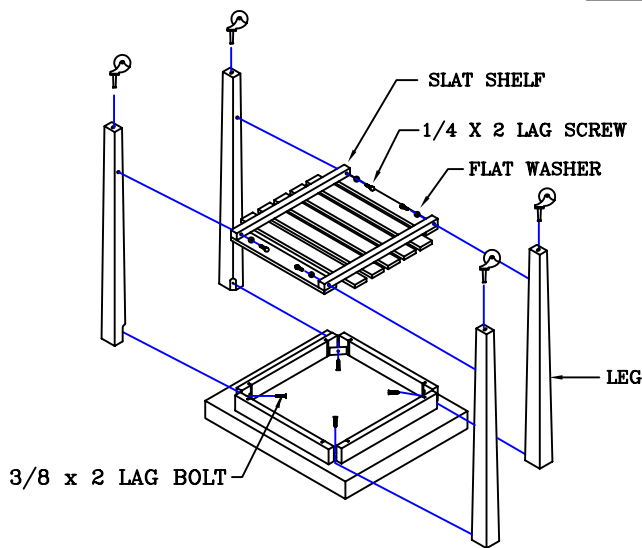

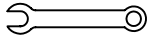

ASSEMBLY INSTRUCTIONS GB BLOCK

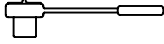

TOOLS REQUIRED	
	OR
7/16 WRENCH AND 9/16 WRENCH	
	
7/16 SOCKET WRENCH AND 9/16 SOCKET WRENCH	

HARDWARE FOR ASSEMBLY	
4 EA. 	1/4"x2" LAG SCREW
4 EA. 	3/8"x2" LAG SCREW
8 EA. 	FLAT WASHER
4 EA. 	BALL CASTER
4 EA. 	GLIDE

INSTRUCTIONS:

- (1) Remove all contents of box, making sure assembly area is flat and clean.
- (2) Place top face down on a rug, carton, or other protected surface.
- (3) Attach each of four legs to the metal brackets at each corner, using one 3/8"x2" lag bolt (washer required). Position legs so shelf mounting holes in lower portion of leg is facing in along the length of the table. Do not fully tighten at this time.
- (4) Fasten shelf to legs using one 1/4"x2" lag bolt and one washer at each hole. (Make sure shelf is positioned face down.) Tighten all hardware at this time.
- (5) Take the nail in glides and nail them into the bottom of each of the four legs. With caster, tap insert into bottom of leg and place caster in insert.
- (6) Turn block upright.

CAUTION: Make certain assistance is available when setting block upright to avoid injury to yourself or the block.

SUGGESTION: Applying bar soap to the bolt or screw threads will make them much easier to insert.

Be sure to follow the maintenance and care guidelines on the enclosed sheet for your new John Boos product.