



ITEM #: \_\_\_\_\_ QTY: \_\_\_\_\_  
 MODEL #: \_\_\_\_\_  
 PROJECT NAME: \_\_\_\_\_

071917

**kitchensource.com**  
 1.800.667.8721

**“ST6-GSK” STAINLESS STEEL TOP WORK TABLES** NSF  
**16GA TOP AND GALV LEGS AND ADJUSTABLE UNDERSHELF**



**FEATURES:**

- 16 GAUGE STAINLESS STEEL TOP
- TYPE 300 STAINLESS STEEL WITH # 4 POLISH, SATIN FINISH
- TOP IS SOUND DEADENED
- REINFORCED WITH 1"X2" CHANNEL RUNNING ENTIRE LENGTH OF TABLE
- 1-1/2" STALLION EDGE ON FRONT AND REAR WITH SIDE EDGES
- 90 DEGREE BEND DOWN FOR TABLE LINE-UP
- GALVANIZED BASE WITH ADJUSTABLE UNDERSHELF
- SHIPPED KNOCKED-DOWN, EASY - TO - ASSEMBLE
- NSF AND CSA CERTIFIED



ST6-3048GSK

**CONSTRUCTION:**

- TOP: STAINLESS STEEL TOPS ARE TIG WELDED, EXPOSED WELDS ARE POLISHED TO MATCH ADJACENT SURFACE.

**MATERIAL:**

- TOP: 16 GAUGE STAINLESS STEEL TYPE 300 STAINLESS STEEL WITH # 4 POLISH, SATIN FINISH
- SHELF: 18 GAUGE GALVANIZED STEEL, (36" WIDE TABLES, 16 GAUGE LOWER SHELF)
- LEGS: 1-5/8" ROUND O.D., 16 GAUGE TUBULAR GALVANIZED STEEL
- GUSSETS: GALVANIZED STEEL
- FEET: 1" ADJUSTABLE GALVANIZED BULLET FEET



ADJUSTABLE SHELF

**16 GAUGE TOP W/ ADJUSTABLE SHELF**

24" WIDE	QTY	30" WIDE	QTY	36" WIDE	QTY
ST6-2424GSK		ST6-3024GSK		ST6-3624GSK	
ST6-2430GSK		ST6-3030GSK		ST6-3630GSK	
ST6-2436GSK		ST6-3036GSK		ST6-3636GSK	
ST6-2448GSK		ST6-3048GSK		ST6-3648GSK	
ST6-2460GSK		ST6-3060GSK		ST6-3660GSK	
ST6-2472GSK		ST6-3072GSK		ST6-3672GSK	
ST6-2484GSK		ST6-3084GSK		ST6-3684GSK	
ST6-2496GSK		ST6-3096GSK		ST6-3696GSK	
ST6-24108GSK		ST6-30108GSK		ST6-36108GSK	
ST6-24120GSK		ST6-30120GSK		ST6-36120GSK	
ST6-24132GSK		ST6-30132GSK		ST6-36132GSK	
ST6-24144GSK		ST6-30144GSK		ST6-36144GSK	

**OPTIONAL ACCESSORIES**

DESCRIPTION	MODEL #	QTY
DRAWER		
DRAWER LOCK		
CASTERS		
OVERSHELVES		
SINKS		
POT RACK		

# DETAILED SPECIFICATIONS

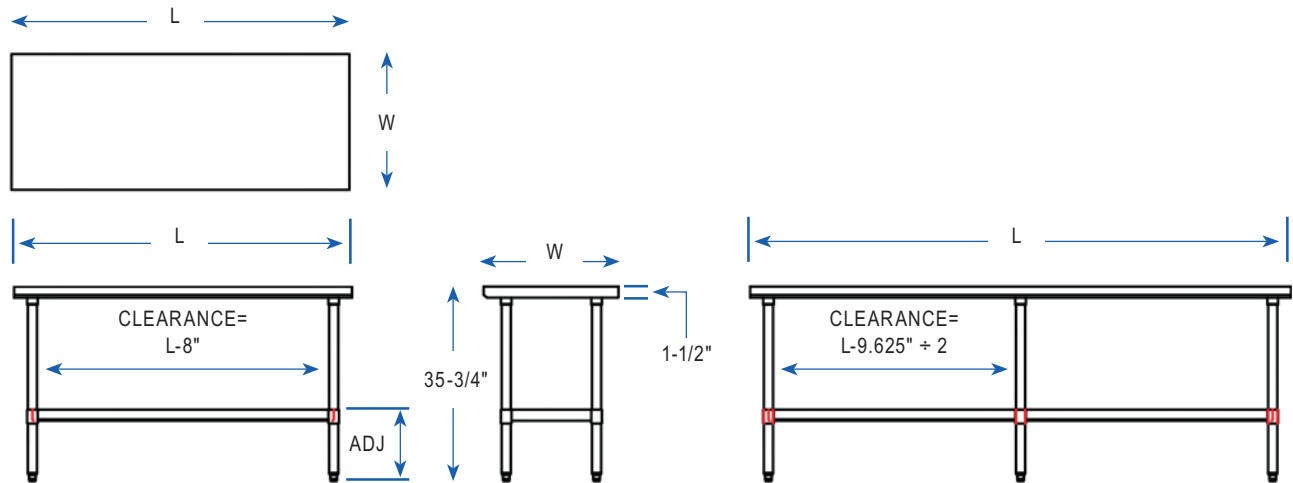

- UNITS 7 FT. AND LARGER ARE FURNISHED WITH SIX LEGS.
- FINISHED SIZE OF UNDERSHELF.  
 SHELF LENGTH = LENGTH MINUS 4.875"  
 SHELF WIDTH = WIDTH MINUS 4.25

## 16 GAUGE TOP W/ ADJUSTABLE SHELF

LENGTH	24" WIDE	WT. (LBS)	30" WIDE	WT. (LBS)	36" WIDE	WT. (LBS)
24"	ST6-2424GSK	36	ST6-3024GSK	44	ST6-3624GSK	50
30"	ST6-2430GSK	40	ST6-3030GSK	50	ST6-3630GSK	59
36"	ST6-2436GSK	52	ST6-3036GSK	59	ST6-3636GSK	75
48"	ST6-2448GSK	64	ST6-3048GSK	76	ST6-3648GSK	82
60"	ST6-2460GSK	76	ST6-3060GSK	92	ST6-3660GSK	98
72"	ST6-2472GSK	97	ST6-3072GSK	111	ST6-3672GSK	144
84"	ST6-2484GSK	108	ST6-3084GSK	125	ST6-3684GSK	135
96"	ST6-2496GSK	118	ST6-3096GSK	139	ST6-3696GSK	155
108"	ST6-24108GSK	130	ST6-30108GSK	153	ST6-36108GSK	171
120"	ST6-24120GSK	167	ST6-30120GSK	167	ST6-36108GSK	187
132"	ST6-24132GSK	157	ST6-30132GSK	165	ST6-36132GSK	185
144"	ST6-24144GSK	172	ST6-30144GSK	198	ST6-36144GSK	192

## MODEL # STRUCTURE

24 = WIDTH OF WORK SURFACE  
 6 = 16GA WORK SURFACE  
 ST = STAINLESS STEEL TOP

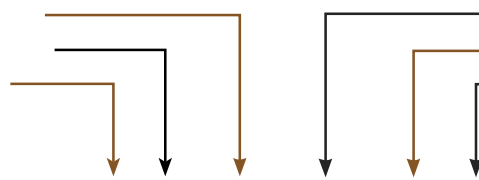

# ST6-2430GSK

SOME UNITS SHIP UNASSEMBLED FOR REDUCED SHIPPING COST. ALL DIMENSIONS ARE TYPICAL. TOLERANCE +/- .500"

John Boos & Co. is constantly engaged in a program of improving products and therefore reserves the right to change specifications without prior notice.