

ASSEMBLY INSTRUCTIONS FOR POT RACK

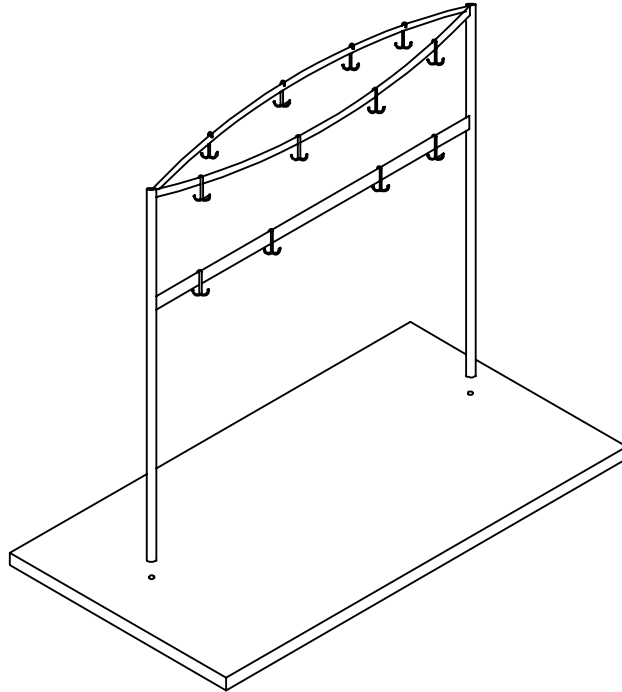

HARDWARE:

- 2 - 1/2 X 3 BOLTS
- 2 - WASHERS
- 12 - 4' POT RACK
- 15 - 5' POT RACK
- 18 - 6' POT RACK

TOOLS REQUIRED:

- 3/4 WRENCH OR RATCHET

INSTRUCTIONS:

NOTE: ASSISTANCE IS REQUIRED FOR ATTACHING POT RACK TO TOP. THIS WILL LESSEN THE CHANCES OF CAUSING DAMAGE TO YOUR TOP.

1. WITH ASSISTANCE, PLACE POT RACK ON TOP OF THE TABLE, LINING UP THE UPRIGHTS OF THE POT RACK WITH THE PRE DRILLED HOLES IN THE TOP OF THE TABLE. (DO NOT SLIDE THE UPRIGHTS ACROSS THE TABLE SURFACE.)

2. TAKE THE 1/2 X 3 BOLTS WITH WASHER AND INSERT THE BOLT through THE BOTTOM OF THE TOP INTO THE UPRIGHTS OF THE POT RACK.

3. ONCE THE BOLTS ARE STARTED, TAKE YOUR WRENCH OR RATCHET AND TIGHTEN THE 1/2" BOLTS, WHILE YOUR ASSISTANT HOLDS THE POT RACK IN PLACE.

4. YOUR POT RACK IS NOW READY FOR USE.

NOTE: IF POT RACK IS SENT OUT FOR USE IN FIELD, CUSTOMER IS REQUIRED TO DRILL TOP FOR POT RACK. ALSO THE HARDWARE SENT MAY NOT WORK ON YOUR TABLE; IT IS THE CUSTOMER'S RESPONSIBILITY TO FIND THE RIGHT HARDWARE TO WORK.