



ITEM #: \_\_\_\_\_ QTY: \_\_\_\_\_  
 MODEL #: \_\_\_\_\_  
 PROJECT NAME: \_\_\_\_\_

051018

**∴kitchensource.com**  
 ☎ 1.800.667.8721

**"CUCD" CUCINA D'AMICO**

**FEATURES:**

- AVAILABLE WITH NORTHERN HARD ROCK MAPLE, AMERICAN BLACK WALNUT OR AMERICAN CHERRY END GRAIN TOP STANDARD BOOS BLOCK CREAM FINISH WITH BEESWAX
- FOOD SERVICE GRADE STAINLESS STEEL BASE AND SHELF
- STAINLESS STEEL TOWEL BAR
- COMMERCIAL GRADE 3" LOCKING CASTERS
- SHIPPED KNOCKED DOWN, 1 CARTON



CUCD15



WAL-CUCD15



CHY-CUCD15

**CUCINA D'AMICO**

MODEL #	QTY
CUCD15	
CHY-CUCD15	
WAL-CUCD15	

# DETAILED SPECIFICATIONS

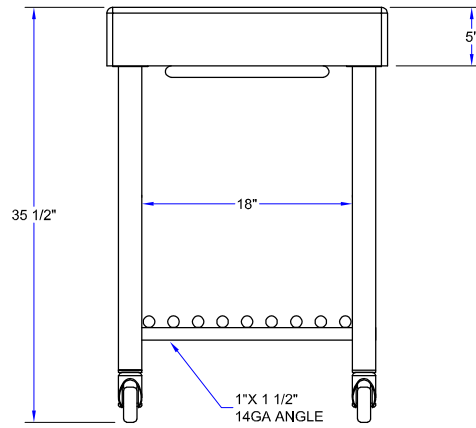
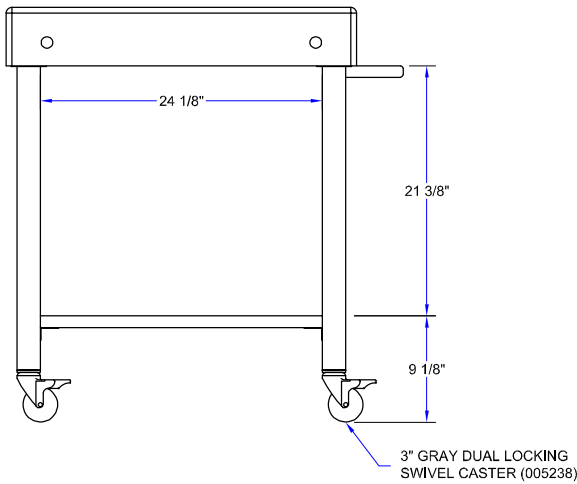
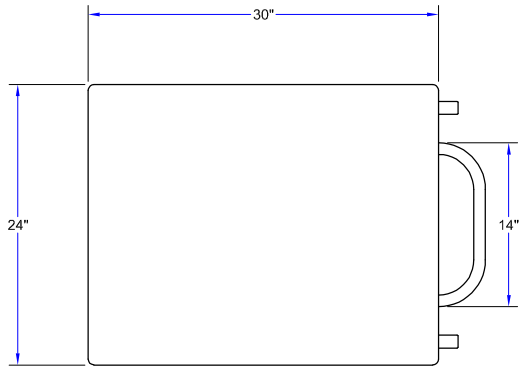

## CUCINA D'AMICO

MODEL #	SIZE	TOP	HEIGHT	WEIGHT (LBS)
CUCD15	30" X 24" X 5"	MAPLE	35-1/2"	135
CHY-CUCD15	30" X 24" X 5"	CHERRY	35-1/2"	114
WAL-CUCD15	30" X 24" X 5"	WALNUT	35-1/2"	129

SOME UNITS SHIP UNASSEMBLED FOR REDUCED SHIPPING COST. ALL DIMENSIONS ARE TYPICAL. TOLERANCE +/- .500"  
 John Boos & Co. is constantly engaged in a program of improving products and therefore reserves the right to change specifications without prior notice.