

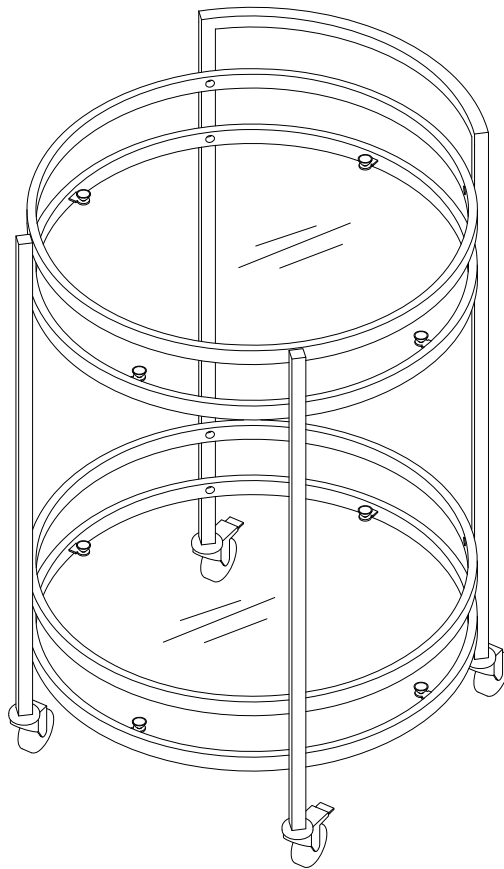

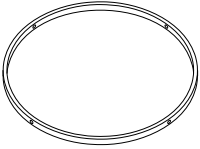

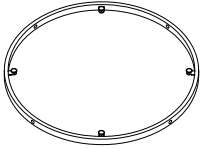

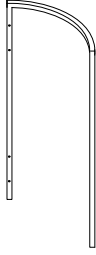

Round Bar Cart CF4009

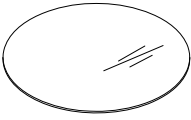

PART LIST

<p>A</p> 	<p>B</p> 	<p>C</p> 	<p>D</p> 	<p>E</p> 
<p>Top Frame 2 PCS</p>	<p>Shelf Frame 2 PCS</p>	<p>Side Frame 1 PC</p>	<p>Leg 2 PCS</p>	<p>Glass 2 PCS</p>
<p>F</p> 	<p>G</p> 			
<p>Locking Caster 2 PCS</p>	<p>Caster 2 PCS</p>			

HARDWARE LIST

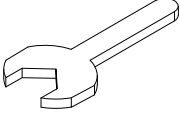
<p>#1</p> 	<p>#2</p> 	<p>#3</p> 
<p>1/4" x 3/4"L Bolt 16 PCS (Extra 1)</p>	<p>Allen Wrench 1 PC</p>	<p>Wrench 1 PC</p>

Step 1. Lay side frame (part C) on a soft flat surface, such as carpet, as shown below. Attach shelf frames (part B) to side frame (part C) using bolts (part #1) and allen wrench (part #2).

NOTE: Please do not fully tighten bolts at this time.

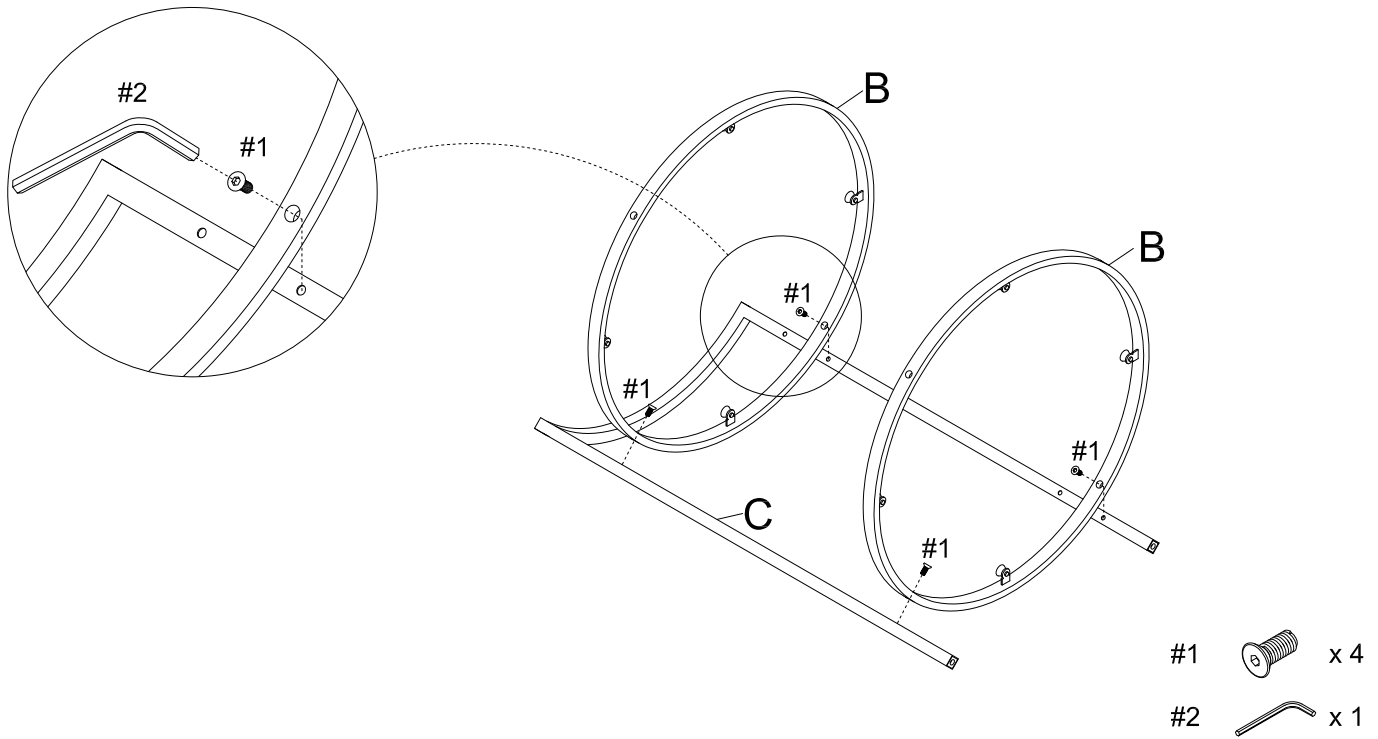

Step 2. Attach top frames (part A) to side frame (part C) using bolts (part #1) and allen wrench (part #2).

NOTE: Please do not fully tighten bolts at this time.

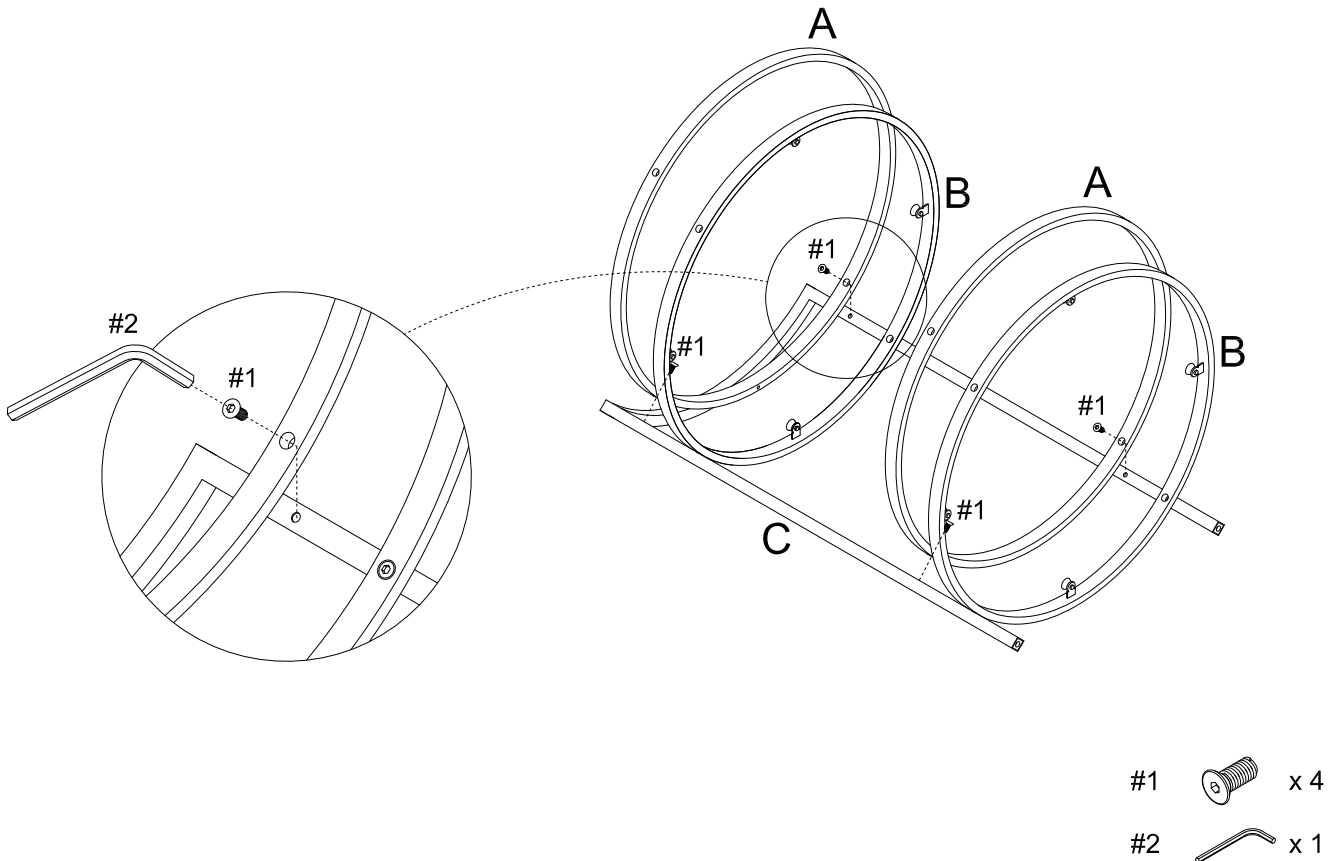

Step 3. Attach legs (part D) to top frames (part A) and shelf frames (part B) using bolts (part #1) and allen wrench (part #2).

NOTE: Please fully tighten all bolts at this time.

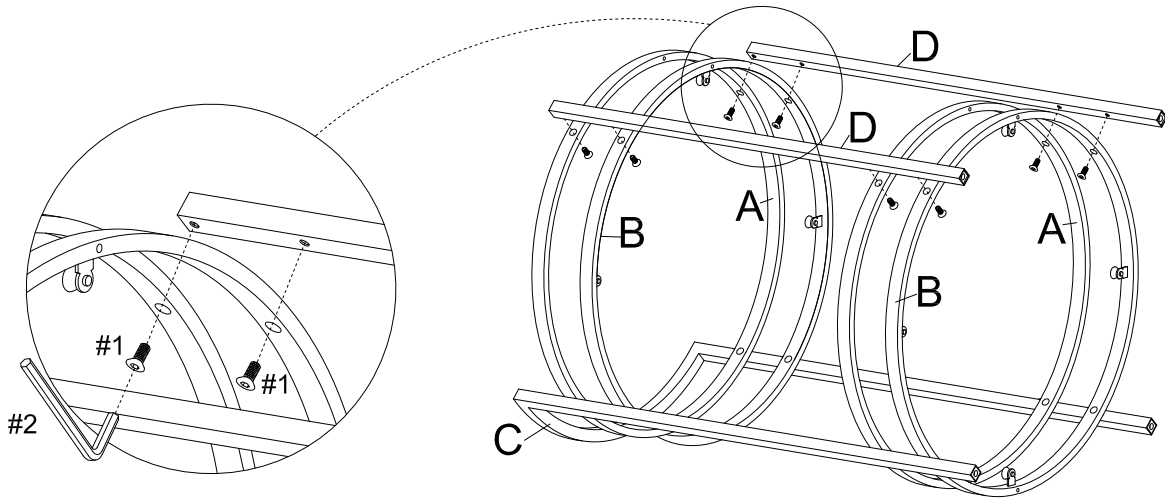

- #1  x 8
- #2  x 1

Step 4. Attach locking casters (part F) and casters (part G) to side frame (part C) and legs (part D) using wrench (part #3).

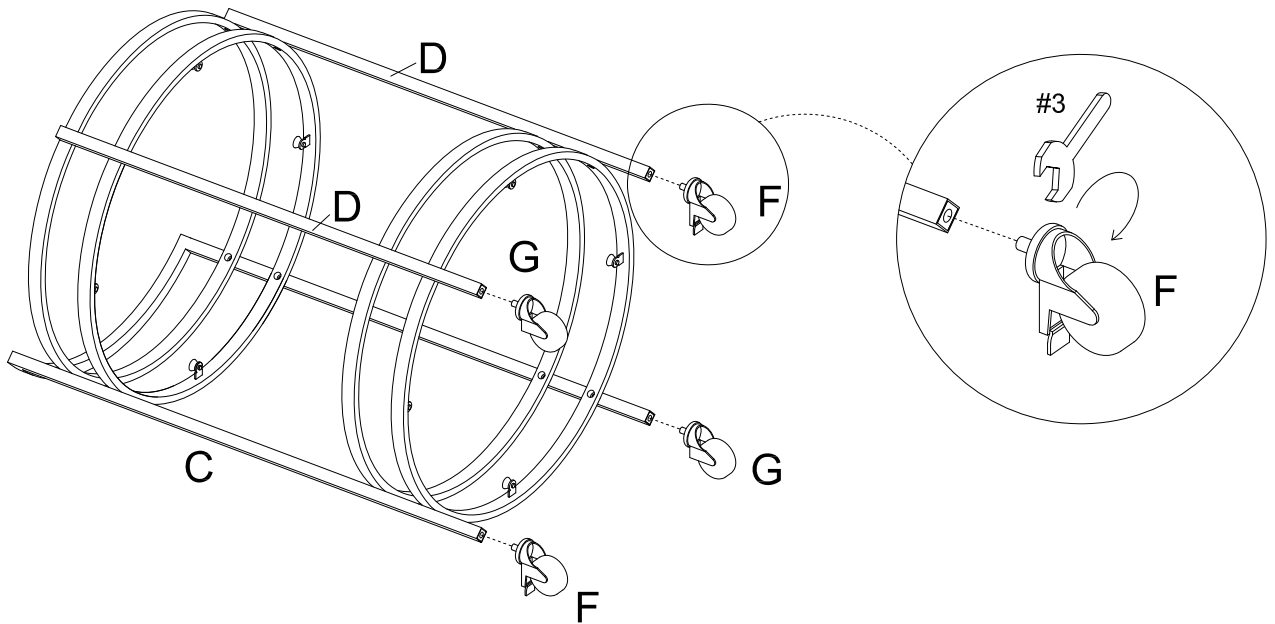

- #3  x 1

Step 5. Carefully turn assembled unit upright, attach glass (part E) to shelf frames (part B).

