

Replacement Parts

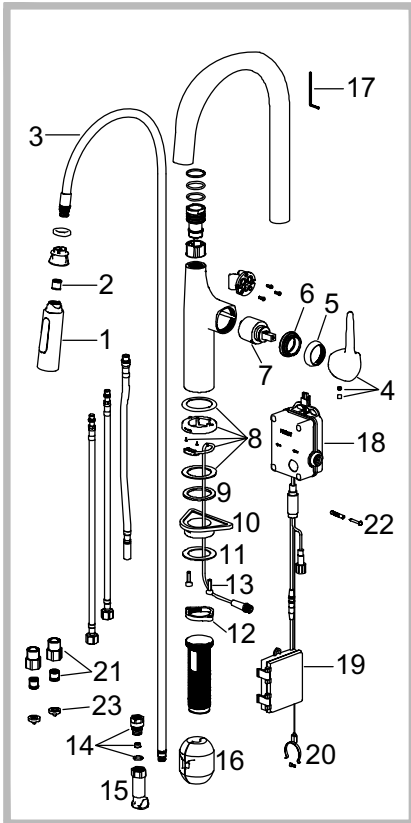

*Denotes faucet component color options:

CH - Chrome
 SFS - Spot Free Stainless Steel
 MB - Matte Black
 BG - Brushed Gold
 WH - White
 BL - Black

Replacement Parts List	Finish/Color	Part #
1. Sprayer Head	CH,SFS,MB,BG*	KP46002
2. Check Valve		KP46025
3. Sprayer Hose	CH,SFS,MB,BG*	KP46001
4. Handle Assembly	CH,SFS,MB,BG*	KP46022
5. Cartridge Cover	CH,SFS,MB,BG*	KP46015
6. Locking Nut		KP46013
7. Cartridge		KP46012
8. LED Base Seat Assembly	CH,SFS,MB,BG*	KP46003
9. Rubber Washer		KP46004
10. Plastic Spacer		KP46005
11. Metal Washer		KP46006
12. Mounting Nut		KP46007
13. Mounting Screw		KP46008
14. 1.8GPM Flow Restrictor	WH*	KP46011
15. Quick Connector		KP46010
16. EZ-Weight		KP46009
17. Hex Key		KP46017
18. Control Box Set		KP46016
19. Battery Housing		KP46018
20. C-clip		KP46020
21. Brass Check Valve		KP46046
22. Control Box Mounting Screw		KP46019
23. Filter Washer		KP46024

Trouble-Shooting

If you have followed the instructions carefully and your faucet still does not work properly, take the following corrective steps:

PROBLEM	CAUSE	ACTION
Leakage under faucet handle	Locking nut has come loose or cartridge needs to be reset.	Remove button located at top of handle. Loosen set screw with hex wrench. Remove handle and unscrew cartridge cover by hand. Tighten locking nut with an adjustable wrench.
Water does not shut off completely	Cartridge may need to be adjusted or replaced.	Remove button located at top of handle. Loosen set screw with hex wrench. Remove handle and unscrew cartridge cover by hand. Unscrew locking nut with an adjustable wrench. Remove ceramic disc cartridge. Check for cracks, and if O-ring is seated correctly. Reseat cartridge.
Leaking between spray head and the hose	Spray head may be loose or washer is not seated correctly in the hose connection.	Tighten spray head by hand until snug. Make sure washer is seated correctly.
Hose does not retract	Weight may be installed incorrectly.	Readjust weight on hose.
Low flow	Aerator may be clogged The screen filter in the hose connectors is dirty.	Unscrew aerator with aerator key. Hold tip of spray head and turn on water to flush debris. Turn off the water supply at water valve and unscrew the hose connectors from water supply lines. Clean the screen in the water lines with hot water, removing any debris or calcium build up.
LED light is not working	The power is not connected. The faucet is in mechanical mode. The faucet has two working modes, Touch and Mechanical. The initial state is Touch mode. Tap (touch) the faucet 5 times in a row to switch to Mechanical mode in order to control water flow with the faucet handle.	Check that the battery box cable is connected, and that the battery is functional and installed correctly. Switch to Touch mode by tapping (touching) the faucet 5 times in a row, or change batteries if needed.

Trouble-Shooting

If you have followed the instructions carefully and your faucet still does not work properly, take the following corrective steps:

PROBLEM	CAUSE	ACTION
Insensitive or ineffective touch control, or no water comes out	The handle is not open.	Open the handle then touch the tube or the body, water will turn on.
	The installed sink is made with stainless steel or marble material, and the shank is too close to or in contact with the sink.	When installing, it is necessary to add additional triangular plastic gaskets to avoid direct contact between the metal parts of the faucet and the sink.
	The power is turned on before the faucet is installed completely.	Confirm that the installation is complete, unplug the battery box cable, and reconnect it.
	Mechanical mode is activated.	If faucet is in Touch mode and battery power is low, tap (touch) the faucet 5 times in a row to switch to Mechanical mode where water flow is controlled by the faucet handle. When the battery is replaced, the faucet will automatically reset to Touch mode.
	The battery box is too close to the control box.	The control box should be at least 3 inches away from the battery box.
	The battery is out of power or installed in the opposite direction.	Check that the battery is functional and installed correctly.
Red LED light is flashing	Low battery	Replace with 4 new batteries.

Care & Maintenance

* To keep the product clean & shining, follow the steps below:

1. Rinse with clean water & dry with a soft cloth
2. Do not clean with soaps, acid, polish, abrasives or harsh cleaners
3. Do not use cloth with a coarse surface
4. Unscrew the aerator and clean when necessary

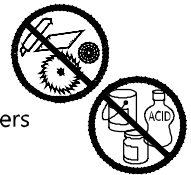

* This installation manual is subject to change without further notice.

Codes/Standards Applicable:



ASME A112.18.1
1.8GPM 6.8L/min maximum

Faucet Warranty

Kraus products are manufactured and tested to the highest quality standards by Kraus USA Inc. ("Kraus").

Kraus extends this warranty to the original purchaser for personal household use of the "Faucet" in its original location. The warranty is non-transferable.

Kraus warrants the structure and finish of the product to be free from defects in material and workmanship under normal usage for the lifetime of the product. The warranty commences from the initial date of purchase by the owner or trade professional, from an authorized Kraus dealer, through the lifetime of the original owner or end-user.

Kraus warrants the mechanical components such as but not limited to sprayhead assembly (includes engine, aerators, structure, restrictors, back flow preventers, sprayer hoses, braided supply line hoses which encompasses nylon, silicon and stainless steel, etc) of the product to be free from defects in material and workmanship under normal usage for a period of one (1) year. The warranty commences from the initial date of purchase by the owner or trade professional, from an authorized Kraus dealer, through the one (1) year term of the original owner or end-user.

Kraus warrants the mechanical component (cartridge) of the product to be free from defects in material and workmanship under normal usage for a period of five (5) years. The warranty commences from the initial date of purchase by the owner or trade professional, from an authorized Kraus dealer, through the five (5) year term of the original owner or end-user.

Kraus warrants all electronic parts other than batteries to be free from defects in material and workmanship for a period of two (2) years. The warranty commences from the initial date of purchase by the owner or trade professional, from an authorized Kraus dealer, through the two (2) year term of the original owner or end-user. No warranty is provided on batteries.

Any product reported to the authorized dealer or to Kraus as being defective within the warranty period will be repaired or replaced with a product of equal value at the option of Kraus. This warranty extends to the original owner or end-user, and is not transferable to a subsequent owner.

Restrictions

This warranty does not cover antediluvian, discontinued, or display products, whether such items are purchased at discount outlets, unauthorized dealers, and/or sold on clearance.

This warranty does not cover instances of negligence, misuse, abuse, improper installation, carelessness, accident, hard water or mineral deposits, exposure to corrosive materials, misapplication, damages caused by improper maintenance, alteration of the product, or failure to follow care or installation instructions enclosed with your product. Avoid using abrasive cleaners such as powders, bleach, ammonia, alcohol, or chlorine. Avoid using abrasive pads, steel wool, or wire brushes, as these will damage and wear down the finish.

This warranty does not apply to Products that have not been installed or operated in accordance with instructions supplied by Kraus and all applicable rules, regulations, and legislation pertaining to such installations.

This warranty does not apply unless the Kraus product is installed by a fully insured and licensed trade professional. Kraus insists that such professionals have experience in the installation of bathroom and kitchen manufactured goods.

This warranty does not cover labor charges or costs of removal and reinstallation of said product. This warranty does not allow recovery of incidental or consequential damages, such as loss of use, delay, property damage, or other consequential damages, and Kraus accepts no liability for such damages.

This warranty does not cover Marine or Outdoor Installation.

Except as otherwise provided above, Kraus makes no warranties, expressed or implied, including warranties of merchantability and fitness for a particular purpose, or compliance with any code.

Shipping charges will be covered for the first (1) year of the warranted replacement part or product (HI, AK, and Puerto Rico shipping charges may apply). International shipping fees are not included.