

Step 5.

Connect the tubing. Wet one end of the tubing sections with water and press it firmly into the inlet port of the filter head. Wet the other end of the tubing and press it firmly into the tee adapter. Repeat for the other end of tubing, pressing one end into the outlet port of the filter head and the other end into the filtered water faucet supply.

IMPORTANT: Use the quick connect lock tabs to prevent any accidental tube release.

Connect the filter water faucet inlet to the filtered water faucet supply. If you have a regular kitchen faucet, connect it to the top of the tee. Place the covers onto the filter head. You may secure the tubing to the cabinet wall using clamps and hardware (not provided).

IMPORTANT: Water from the supply line must be connected to the filter head inlet. Water from the filter head outlet must be connected to the faucet. System performance and filter capacity will be compromised if connected incorrectly.

NOTE: 8 feet of tubing is provided. When cutting the tubing use a sharp utility knife to make clean and square cuts. Cut the tubing to the lengths needed between the faucet and filtration system and the filtration system and water supply.

⚠ CAUTION - To avoid the risk of personal injury, wear cut resistant gloves with non-slip grip when cutting.

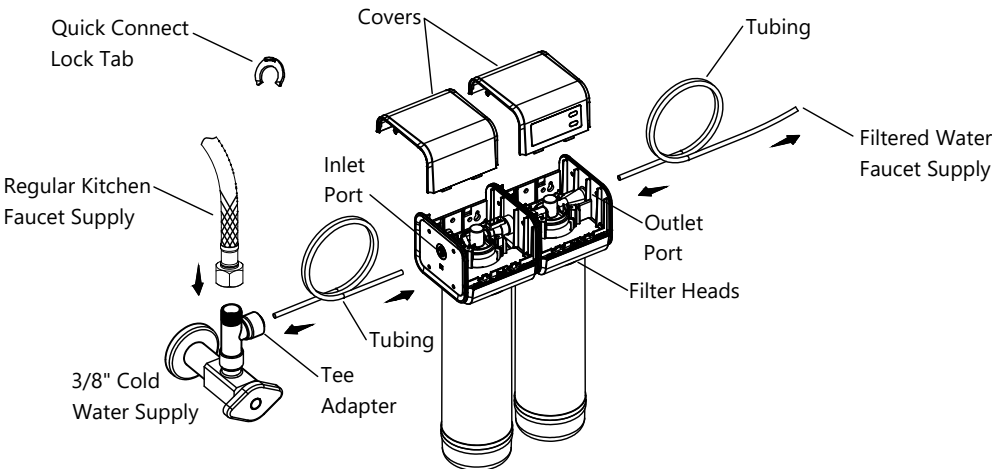

Step 6.

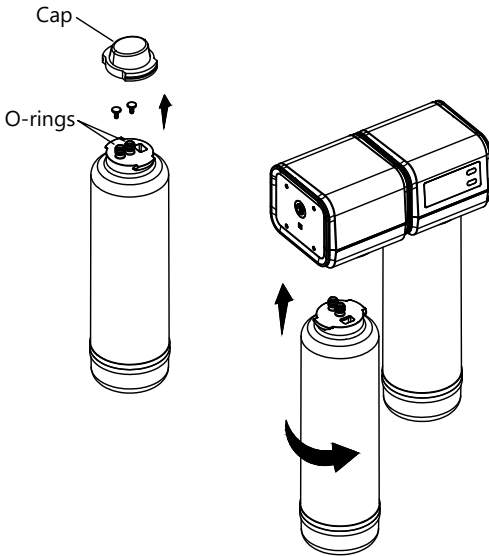

Install the filter cartridges. Write the date on the new filter cartridge label. Remove the cap from the filter cartridge and discard. Inspect the cartridge for any damage. Make sure both sets of O-rings are present and are positioned correctly. Align the filter cartridge as shown and press upward into the filter head. Rotate the filter cartridge counterclockwise 90° until it is secure in the filter head. Repeat for the second cartridge.

IMPORTANT: The Polypropylene Cartridge must be on the left side. The Compressed Carbon Cartridge must be on the right side below the LCD screen.

IMPORTANT: Replace cartridges at the same time to maintain a proper performance.

Step 7.

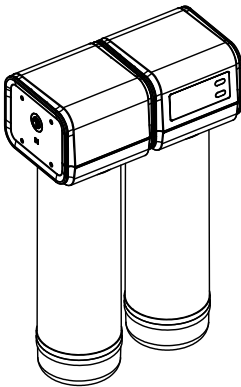

Turn on the cold water supply valve and check all connections for leaks. Run the water for at least 5 minutes to remove any air and carbon particles in the system.

Step 8.

Display & Reset:

After installing new filters push and hold the settings button for 3 seconds. Filter 1 icon will blink. Push the reset button and hold for 3 seconds and the icon will reset to full capacity. Push the settings button again and filter 2 icon will blink. Push and hold the reset button for 3 seconds and the icon will reset to full capacity. Push the settings button to exit the reset mode.

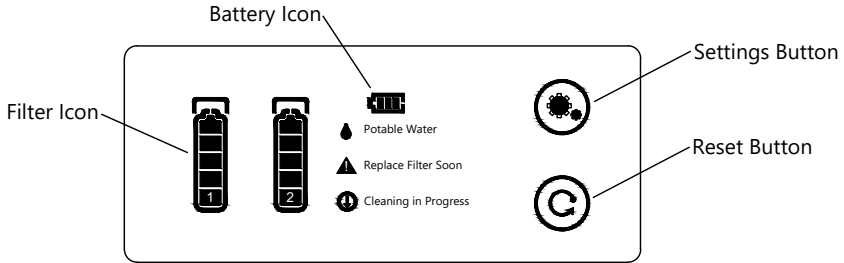

Flush:

When installing new filters, you must flush for a minimum of 10 minutes, the flush icon will blink until done. If filters have not been used for more than 3 days, the flush icon will blink. Flush for a minimum of 5 minutes.

Potable Water Icon:

The Potable Water icon will blink when the filter is ready for use.

⚠ CAUTION - Do not drink the water before the Potable Water icon blinks.

Filter Icon:

The Filter Icon represents the 2 filters for the FF-1000 filter unit. Indication of 5 bars show a new filter, 100% capacity, 4 bars 50-75% capacity, 3 bars 25-50% capacity, 2 bars 5-25% capacity, 1 bar less than 5% capacity. When below a 5% capacity the Filter Icon will blink, and the unit will buzz every 6 seconds when the water is flowing. At 0% filter capacity the icon will blink constantly.

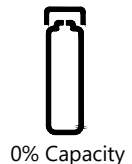

Battery Icon:

When the batteries reach below 10% capacity the Battery Icon will blink and a warning light will come on.



Cleaning in Progress Icon:

The conditions that initiate the cleaning process are when the filter has not been used for three days or after the filters are replaced. If any of the two conditions are met, the "cleaning" starts. The "Cleaning in Progress" icon starts to blink. The cleaning takes ten minutes. It stops blinking after ten minutes when the cleaning is completed.

Troubleshooting

If you have followed the instructions carefully and your faucet still does not work properly, take the following corrective steps:

PROBLEM	CAUSE	ACTION
Water leaks between the filter head and the filter cartridge.	An O-ring is damaged, dirty, or out of place.	Turn off the water supply, and relieve water pressure. Remove the filter cartridge and inspect the O-rings for damage or debris, and ensure that the O-rings are in place. Reinstall the filter cartridge, turn on the water supply, and check for water leakage.
Water leaks at a tubing connection.	Tubing is not cut square, or is damaged or crimped.	Turn off the water supply, and relieve water pressure. Remove the Quick Connect Lock Tab. Press in the collar around the fitting at the leak, and pull the tubing to remove. Use a sharp utility knife to cut 1/2" (13 mm) off the end of the tubing. Reinsert the tubing into the fitting. Turn on the water supply and check for leakage.
Water leaks at a threaded connection.	The connection is damaged or dirty.	Turn off the water supply, and relieve water pressure. Disconnect the fitting, and inspect the seal for damage or debris. Remove any debris or replace the damaged fitting. Securely reconnect the fitting. IMPORTANT - DO NOT overtighten. Turn on the water supply and check for leakage.

Replacement Parts

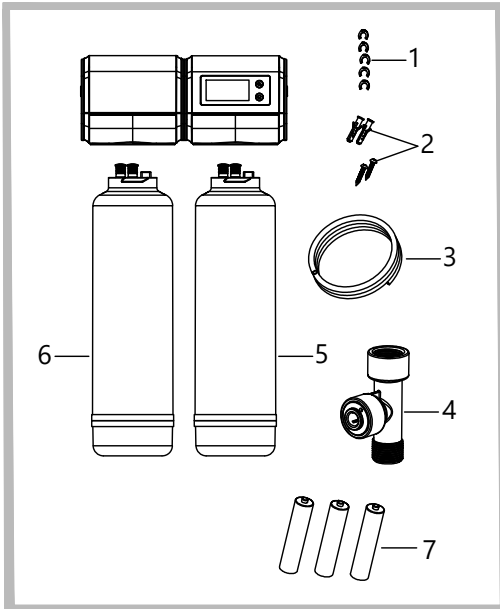

Replacement Parts List	Part #	Source
1. Quick Connect Lock Tab	KP26063	DMT
2. Mounting Screws & Anchors	KP26061	Keruichuang & Shengfa
3. Tubing 1/4" x 8'	KP26062	Zhongdenuo
4. Tee Adapter	KP26064	Meigu
5. Compressed Carbon Cartridge	KF-1CB	Filtertech
6. Polypropylene Cartridge	KF-1PP	Filtertech
7. 3x AAA Batteries*		Regular compliance

* - Batteries provided with initial purchase only

This system has been tested according to NSF/ANSI 42, 53 and 401 for reduction of the substances listed below. The concentration of the indicated substances in water entering the system was reduced to a concentration less than or equal to the permissible limit for water leaving the system as specific in NSF/ANSI 42, 53 and 401.

Performance Data Sheet

Model: FS-1000

Replacement Filters: FC-100PP and FC-100CB

Substance	Influent Challenge Concentration	Minimum % Reduction or Maximum Product Water Concentration Requirement
chlorine	2.0 mg/L \pm 10%	\geq 50%
particulate, Class I particles 0.5 to $<1 \mu\text{m}$	at least 10,000 particles/mL	\geq 85%
lead	0.15 mg/L \pm 10%	0.005 mg/L
Bisphenol A	2000 ng/L \pm 20%	300 ng/L
Estrone	140 ng/L \pm 20%	20 ng/L
Ibuprofen	400 ng/L \pm 20%	60 ng/L
Naproxen	140 ng/L \pm 20%	20 ng/L
Nonylphenol	1,400 ng/L \pm 20	200 ng/L
Phenytoin	200 ng/L \pm 20%	30 ng/L
Chloroform (VOC Surrogate)	0.300 mg/L \pm 10%	\geq 95%
PFOA (perfluorooctanoic acid CAS #335-67-1)	0.0015 mg/L \pm 10%	0.00007 ² mg/L
PFOS (perfluorooctane sulfonate CAS #1763-23-1)	0.0015 mg/L \pm 10%	0.00007 ² mg/L

Requirement in Iowa - The seller shall retain the signed PDS on file at the seller's place of business for at least two years:

Buyer _____ Date _____

Seller _____ Date _____

Performance Data Sheet

(based on VOC surrogate testing)

Substance	Influent Challenge Concentration mg/L	Minimum % Reduction or Maximum Product Water Concentration Requirement mg/L
alachlor	0.050	0.001
atrazine	0.100	0.003
benzene	0.081	0.001
carbofuran	0.190	0.001
carbon tetrachloride	0.078	0.0018
chlorobenzene	0.077	0.001
chloropicrin	0.015	0.0002
2,4-D	0.110	0.0017
dibromochloropropane (DBCP)	0.052	0.00002
o-dichlorobenzene	0.080	0.001
p-dichlorobenzene	0.040	0.001
1,2-dichloroethane	0.088	0.0048
1,1-dichloroethylene	0.083	0.001
cis-1,2-dichloroethylene	0.170	0.0005
trans-1,2-dichloroethylene	0.086	0.001
1,2-dichloropropane	0.080	0.001
cis-1,3-dichloropropylene	0.079	0.001
dinoseb	0.170	0.0002
endrin	0.053	0.00059
ethylbenzene	0.088	0.001
ethylene dibromide (EDB)	0.044	0.00002
haloacetonitriles (HAN)		
bromochloroacetonitrile	0.022	0.0005
dibromoacetonitrile	0.024	0.0006
dichloroacetonitrile	0.0096	0.0002
trichloroacetonitrile	0.015	0.0003
haloketones (HK)		
1,1-dichloro-2-propanone	0.0072	0.0001
1,1,1-trichloro-2-propanone	0.0082	0.0003
heptachlor	0.025	0.00001
heptachlor epoxide	0.0107	0.0002
hexachlorobutadiene	0.044	0.001
hexachlorocyclopentadiene	0.060	0.000002
lindane	0.055	0.00001
methoxychlor	0.050	0.0001
pentachlorophenol	0.096	0.001
simazine	0.120	0.004
styrene	0.150	0.0005
1,1,2,2-tetrachloroethane	0.081	0.001
tetrachloroethylene	0.081	0.001
toluene	0.078	0.001
2,4,5-TP (silvex)	0.270	0.0016
tribromoacetic acid	0.042	0.001
1,2,4-trichlorobenzene	0.160	0.0005
1,1,1-trichloroethane	0.084	0.0046
1,1,2-trichloroethane	0.150	0.0005
trichloroethylene	0.180	0.001
trihalomethanes (includes)		
chloroform (surrogate chemical)	0.300	0.015
bromoform		
bromodichloromethane		
chlorodibromomethane		
xylenes (total)	0.070	0.001

Codes/Standards Applicable:



The system is certified by IAPMO R&T according to NSF/ANSI 42 standard for material safety, structural integrity, chlorine, particulate I; NSF/ANSI 53 standard for Lead, VOC and PFOA/PFOS reduction; NSF/ANSI 401 standard for Bisphenol A, Phenytoin, Ibuprofen, Naproxen, Estrone, Nonylphenol and NSF/ANSI 372 for low lead compliance. See Performance Data Sheet for individual contaminants and reduction performance.

System conforms to NSF/ANSI 42, 53, 401 and 372 for the specific performance claims as verified and substantiated by test data.

While testing was performed under standard laboratory conditions, actual performance may vary.

All-in-One Filtration Set - Limited Warranty

Kraus[®]USA Plumbing, LLC extends this warranty to the original consumer and commercial purchasers of the All-in-One Filtration Set (the "Product") when purchased from an authorized Kraus dealer and in the location of original installation. This warranty is non-transferable.

Kraus warrants the structure and finish of the Product to be free from defects in material and workmanship under normal usage for a period of one (1) year from the date of purchase by a trade professional or end-user of the Product from an authorized Kraus dealer.

Any product reported to the authorized dealer or to Kraus as being defective within the warranty period will be repaired or replaced with a product of equal value at the option of Kraus.

Care Instructions

The filters must be replaced every six (6) months or when the 700 gallon capacity has been exceeded, whichever comes first. You may also need to replace if you notice a decrease in water flow.

What is Not Covered

This warranty does not cover Products that were discontinued when purchased or display Products, whether such Products were purchased at discount outlets, unauthorized dealers, and/or sold on clearance. This warranty does not cover any free gifts included with purchase.

This warranty does not cover damage resulting from neglect, misuse (including use for an unintended application), abuse, carelessness, accident, hard water or mineral deposits, exposure to corrosive materials, improper maintenance, alteration of the Product, failure to follow care, cleaning or installation instructions enclosed with your Product. Kraus recommends that all Kraus Products be installed by a fully licensed and insured trade professional with experience in the installation of bathroom and/or kitchen manufactured goods.

How to Make a Warranty Claim

If you are a **consumer purchaser**, please contact a Kraus Customer Service Representative at:

Kraus® USA Plumbing, LLC
12 Harbor Park Drive
Port Washington, NY 11050
Toll-free 800-775-0703
Customerservice@kraususa.com

If you are a **plumbing contractor or trade professional**, please contact a Kraus Pro Representative at:

Kraus USA Plumbing, LLC
12 Harbor Park Drive
Port Washington, NY 11050
516-801-8955
Proservice@kraususa.com

If you are an **authorized partner**, please contact a Partner Support Representative at:

Kraus USA Plumbing, LLC
12 Harbor Park Drive
Port Washington, NY 11050
516-801-8954
Partnersupport@kraususa.com

In requesting warranty service, please be ready to provide your proof of purchase and a description of the problem. Shipping charges will be covered for the first (1) year of the warranted replacement part or product (HI, AK, and Puerto Rico shipping charges may apply). International shipping fees are not included.

Limitation on Duration of Implied Warranties

Please note that some states/provinces (including Quebec) do not allow limitations on how long an implied warranty lasts, so the below limitations may not apply to you. TO THE MAXIMUM EXTENT PERMITTED BY APPLICABLE LAW, ANY IMPLIED WARRANTY, INCLUDING THE IMPLIED WARRANTIES OF MERCHANTABILITY AND OF FITNESS FOR A PARTICULAR PURPOSE, IS LIMITED TO THE STATUTORY PERIOD OR THE DURATION OF THIS WARRANTY, WHICHEVER IS SHORTER.

Limitation of Special, Incidental or Consequential Damages

Please note that some states/provinces (including Quebec) do not allow the exclusion or limitation of special, incidental or consequential damages, so the below limitations and exclusions may not apply to you. TO THE MAXIMUM EXTENT PERMITTED BY APPLICABLE LAW, THIS WARRANTY DOES NOT COVER, AND KRAUS USA PLUMBING, LLC SHALL NOT BE LIABLE FOR, ANY SPECIAL, INCIDENTAL OR CONSEQUENTIAL DAMAGES (INCLUDING LABOR CHARGES TO REPAIR, REPLACE, INSTALL OR REMOVE THIS PRODUCT), WHETHER ARISING OUT OF BREACH OF ANY EXPRESS OR IMPLIED WARRANTY, BREACH OF CONTRACT, TORT, OR OTHERWISE.

This warranty gives you specific legal rights, and you may also have other rights which vary from state/province to state/province.

Download the Kraus Care & Maintenance Guide at:
<http://www.kraususa.com/maintenance>

IMPORTANT

Register Your Kraus® Product

Activate Your Warranty

Access Premium Customer Support

Get Product Information

REGISTER TODAY

<http://www.kraususa.com/registration>



Kräus®
www.kraususa.com