

# Vanity with Mirror

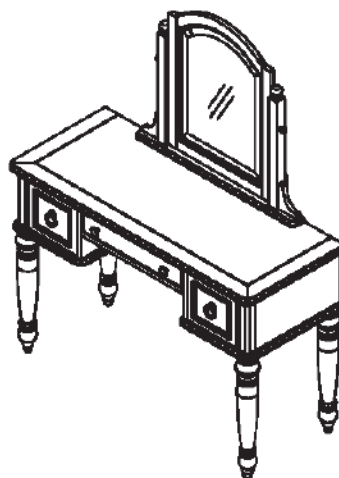

## IMPORTANT

Carefully remove all the parts from the carton and place them individually on a soft cloth to prevent scratches or other damage.

Carefully and strictly follow these assembly instructions to ensure a completed product as designed.

Do not use power tools above 8 volts to assemble.

### Part List

- F. Top 1 pc.
- A. Mirror 1 pc.
- E. Batten 2 pcs.
- N. Back Panel 1 pc.
- D. Mirror Base 1 pc.
- B. Mirror Support 1 pc.
- C. Mirror Support 1 pc.
- K. Front Rail 1 pc.
- L. Bottom 1 pc.
- M. Bottom 1 pc.
- P. Drawer 2 pcs.
- G. Side Panel 1 pc.
- H. Side Panel 1 pc.
- I. Divider 1 pc.
- J. Divider 1 pc.
- O. Leg 4 pcs.
- Q. Drawer 1 pc.

Refer to later page(s) of these instructions for drawer assembly.

### Hardware List

Hex Wrench 1 pc.	Hex Wrench (small) 1 pc.	Cam Lock Screw 24 pcs. (+4 extra)	Cam Lock 24 pcs. (+4 extra)	M4x32 1 1/4" Round Head Screw 12 pcs. (+1 extra)	M4x25 1" Round Head Screw 4 pcs. (+1 extra)
M3x32 1 1/4" Flat Head Screw 24 pcs. (+1 extra)	M3x19 3/4" Flat Head Screw 10 pcs. (+1 extra)	M6x30 Head Cap Bolt 8 pcs. (+1 extra)	Spring Washer 8 pcs. (+1 extra)	Flat Washer 8 pcs. (+1 extra)	M6x68 Axis Bolt 2 pcs.
Mirror Axis 2 pcs.	Plastic Washer 2 pcs. (+1 extra)	5/32"x1/2" Machine Screw (Short) 2 pcs.	Handle 2 pcs.	5/32"x7/8" Machine Screw (long) 2 pcs.	Knob 2 pcs.
					Dowel 16 pcs. (+1 extra)

Tool(s) required for assembly: Phillips screwdriver, Level, Pencil, Drill (8 volts or less), 3/8" Drill Bit

## Assembly Instructions 2/11

### IMPORTANT

- Use a soft cloth between these parts and the floor.
- Do not use power tools above 8 volts to assemble.
- Do not tighten all the screws until each part is properly assembled.
- The unit must be level to work properly. Use the included adjustable levelers to level.
- Keep Hex Wrench as the Bolts may need to be tightened in the future.

### STEP 1

Insert Cam Lock Screws into pre-drilled holes in Top (F), Side Panels (G), (H), Dividers (I), (J) and Back Panel (N), then tighten.

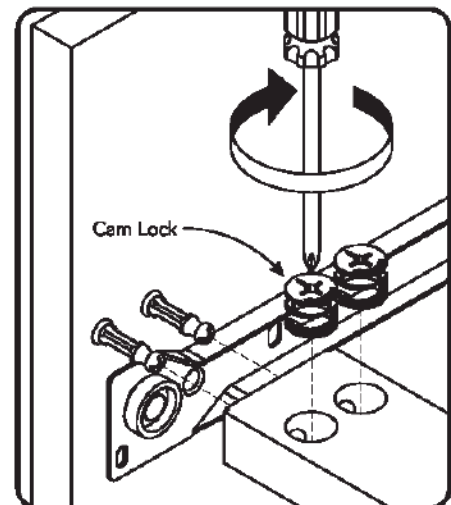
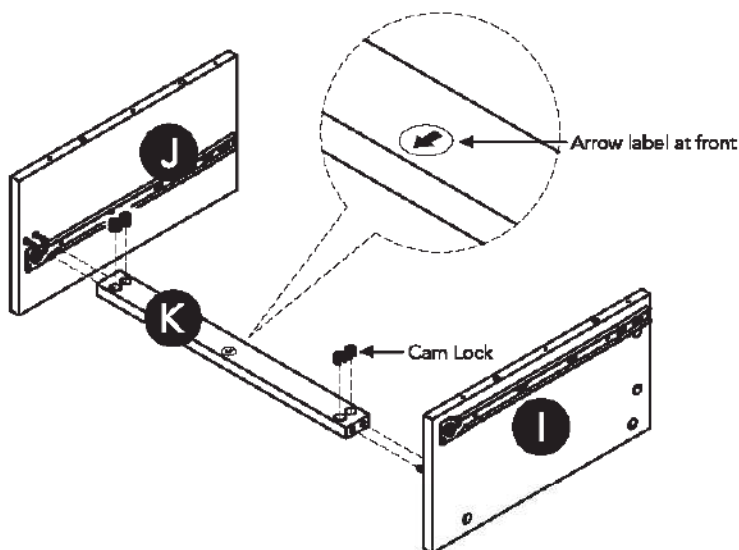
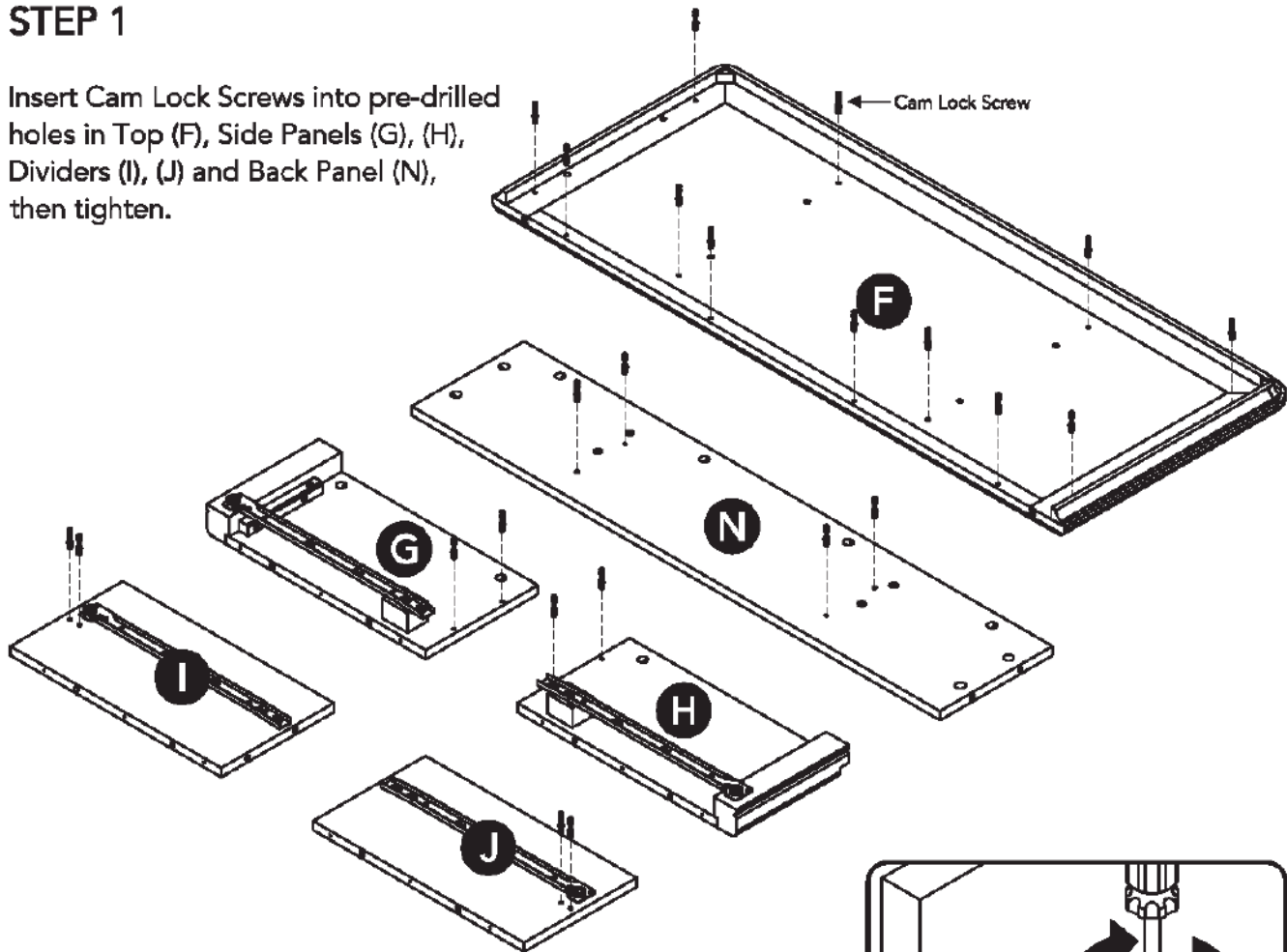

Figure 1

### STEP 2

Orientate Front Rail (K) with Arrow label at front, then attach Dividers (I) and (J) to Front Rail (K) with Cam Locks. (See Figure 1)

# Assembly Instructions 3/11

## STEP 3

Attach unit and Side Panels (G) and (H) to Back Panel (N) with Cam Locks.  
(See Figure 1)

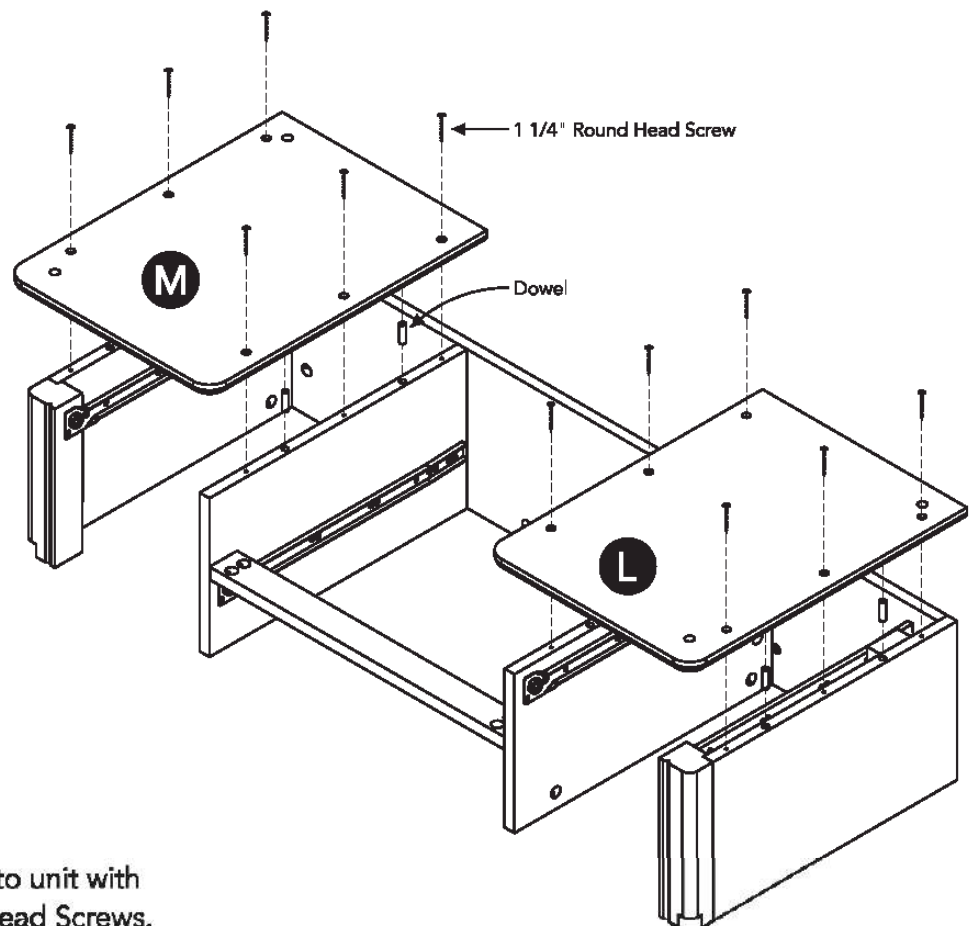
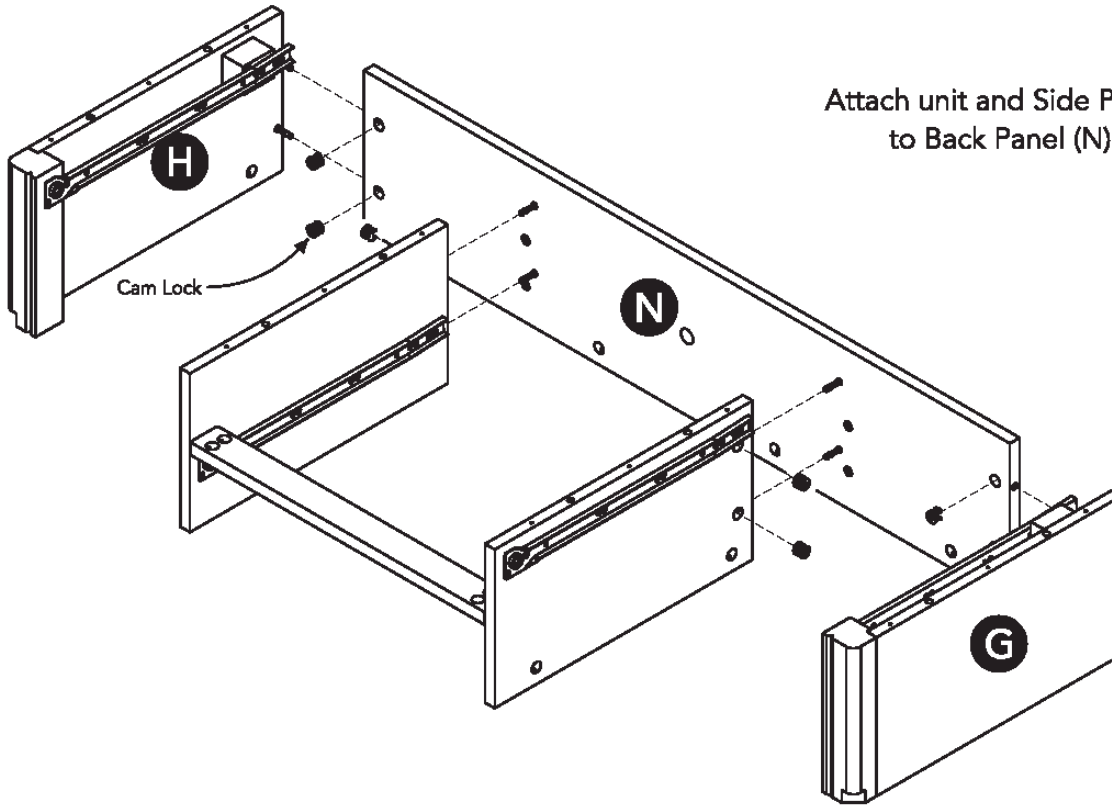

## STEP 4

Attach Bottoms (L) and (M) to unit with Dowels and 1 1/4" Round head Screws.

**STEP 5**

Attach Legs (O) to unit.

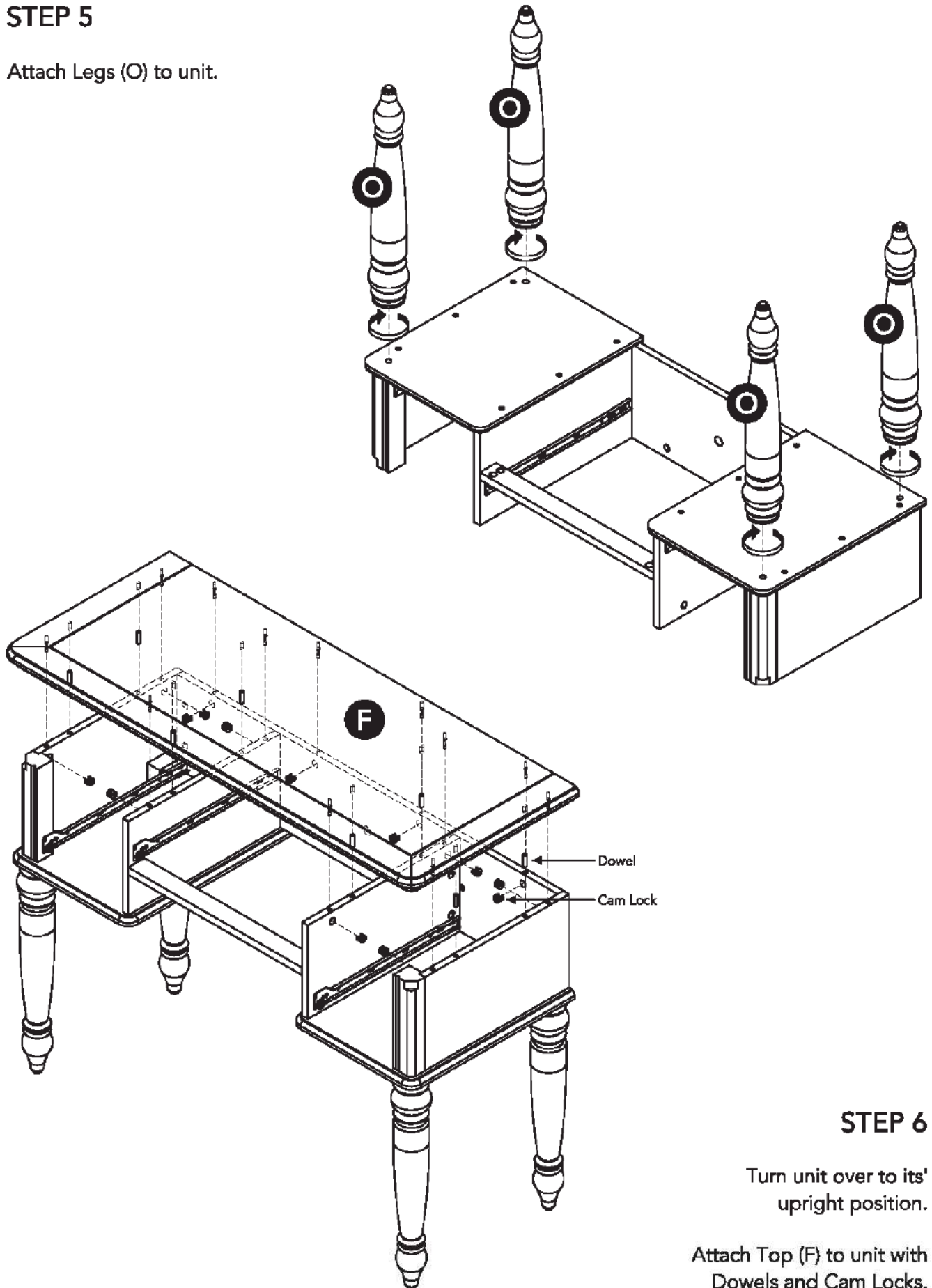

**STEP 6**

Turn unit over to its' upright position.

Attach Top (F) to unit with Dowels and Cam Locks.

## STEP 7

Attach Mirror Base (D) to Mirror Supports (B) and (C) with 1" Round Head Screws.

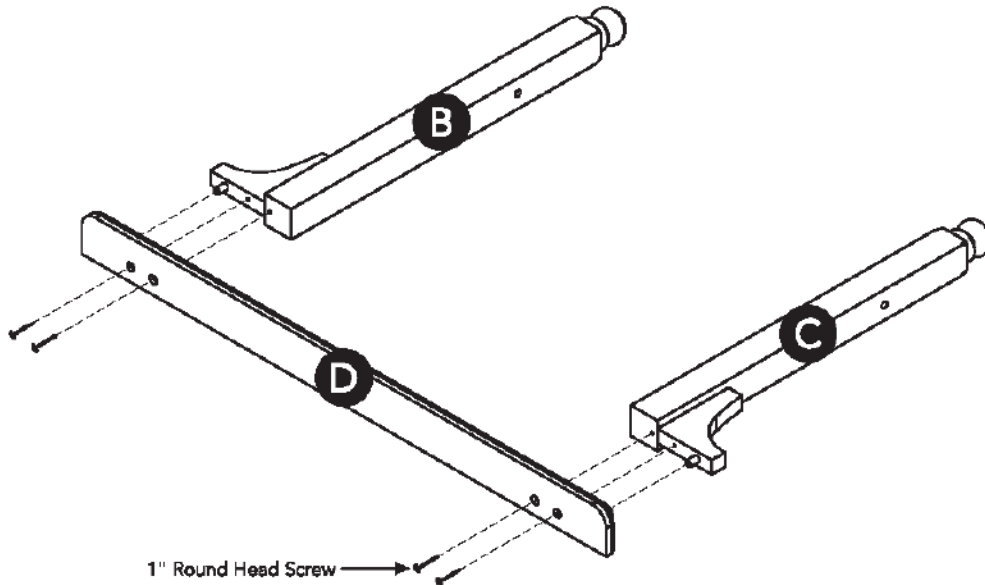

## STEP 8

Attach Mirror (A) to unit with Axis Bolts, Mirror Axes and Plastic Washers.  
(See Figure 2)

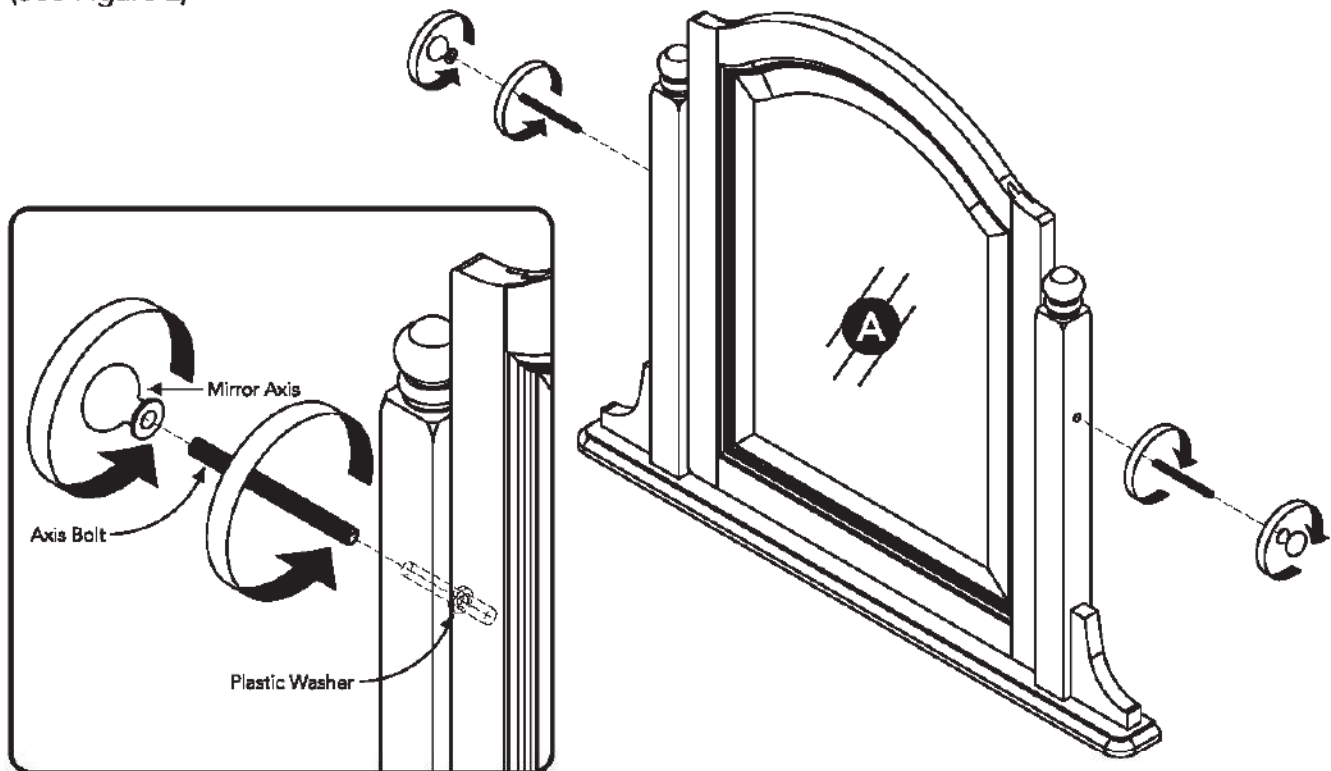

Figure 2

## Assembly Instructions 6/11

### STEP 9

Attach Battens (E) to unit from Step 6 and unit from Step 8 with Bolts, Spring Washers and Flat Washers.

Tighten Bolts with Hex Wrench. (See Figure 3)

Level unit by adjusting the adjustable levelers on bottom of unit. (See Figure 4)

Note : unit must be level to work properly.

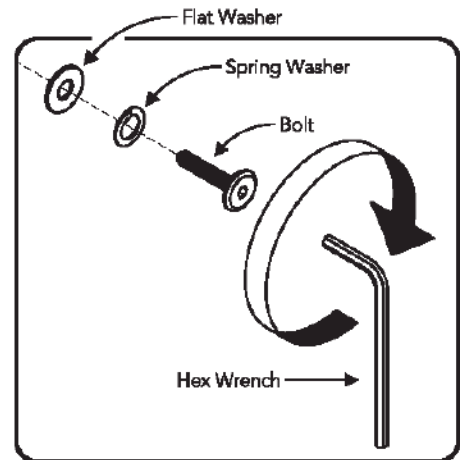
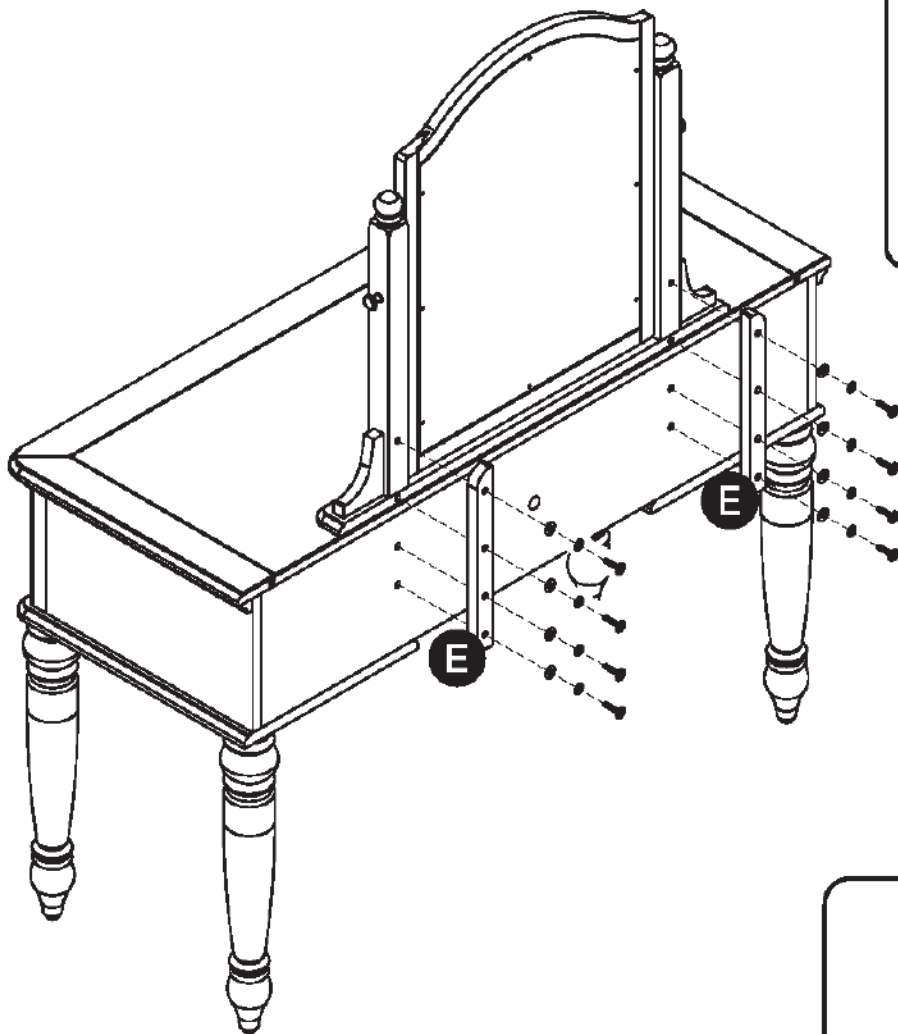

Figure 3

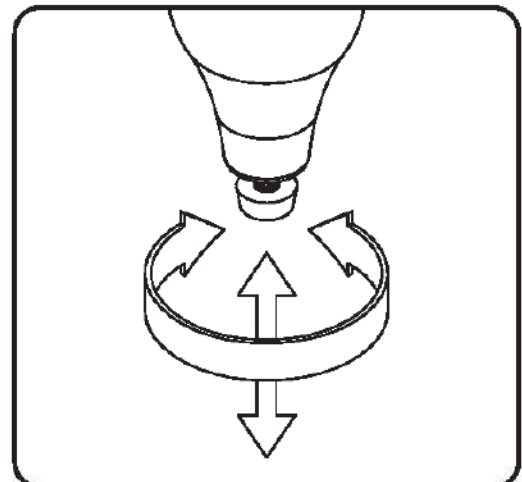

Figure 4

# Assembly Instructions 7/11

## IMPORTANT

• To help reduce the risk of the unit tipping over, the Tip-over Restraint must be installed following these instructions exactly.

## STEP 10

Place unit at desired location.

Mark wall with pencil to show position of hole in Back Panel (N). (See Figure 5)

Move unit.

Drill a 3/8" hole in wall 1" below mark.

Insert Anchor into the wall hole and attach Tip-over Restraint to Anchor with 1 1/2" Round Head Screw and Flat Washer. (See Figure 6)

Move unit back into place and insert Tip-over Restraint into unit through hole in Back Panel (N). (See Figure 7)

Attach Tip-over Restraint to unit with 1/2" Round Head Screw and Flat Washer. (See Figure 8)

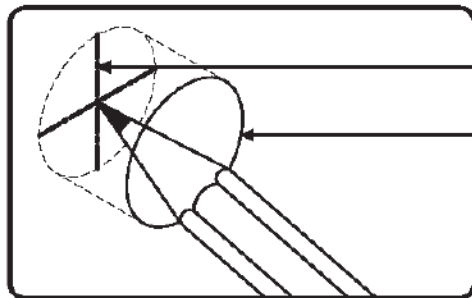
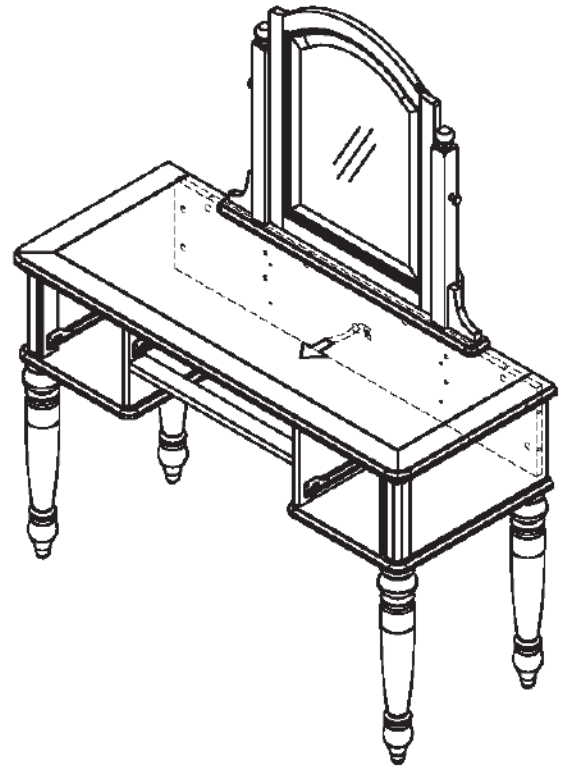

Figure 5

Pencil mark

Hole in Back Panel (N)

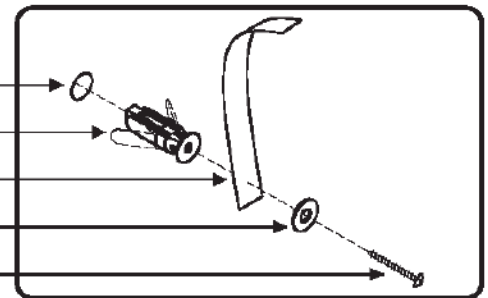

Figure 6

3/8" wall hole

Anchor in wall

Tip-over Restraint

Flat Washer

1 1/2" Round Head Screw

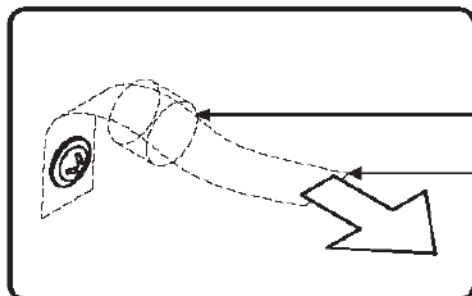

Figure 7

Hole in Back Panel (N)

Tip-over Restraint

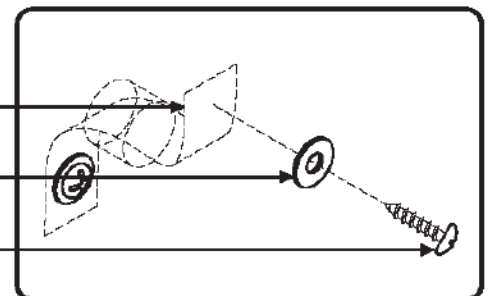

Figure 8

Tip-over Restraint

Flat Washer

1/2" Round Head Screw

## Hardware List



Tip-over Restraint  
1 pc.



Anchor  
1 pc. (+1 extra)



M3x38  
1 1/2" Round Head Screw  
1 pc. (+1 extra)



M3x13  
1/2" Round Head Screw  
1 pc. (+1 extra)



Flat Washer  
2 pcs. (+1 extra)

# Drawer (P)

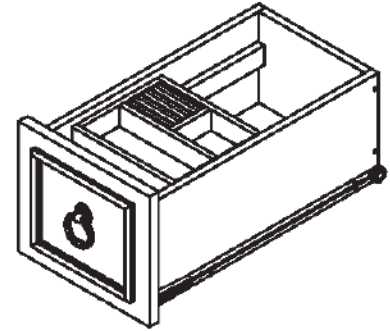

## STEP 12

Attach Drawer Sides (P3) and (P4) to Drawer Back (P2) with 1 1/4" Flat Head Screws.

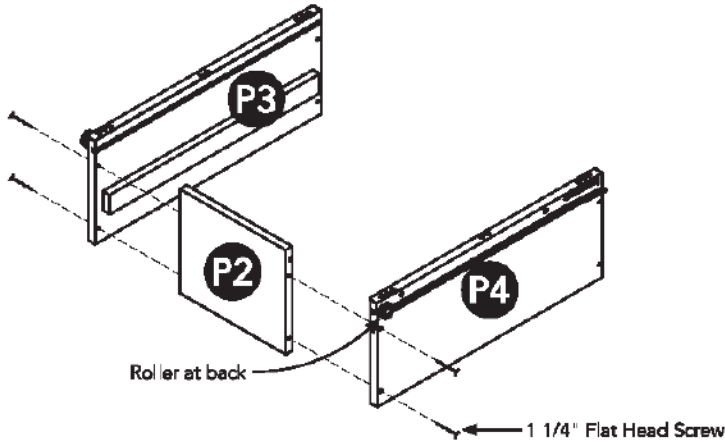

## STEP 13

Insert Drawer Bottom (P5) into groove.

Attach Drawer Front (P1) to unit with 1 1/4" Flat Head Screws.

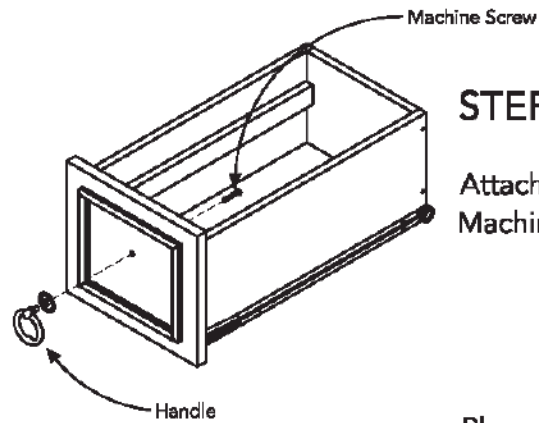
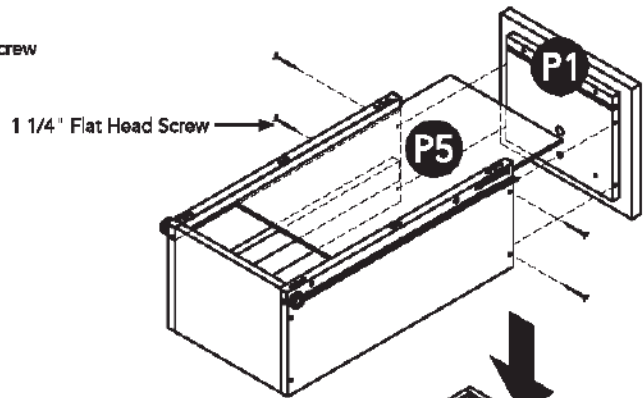

## STEP 14

Attach Handle with Machine Screw (short).

## STEP 15

Place Jewelry Box (P6) into position.

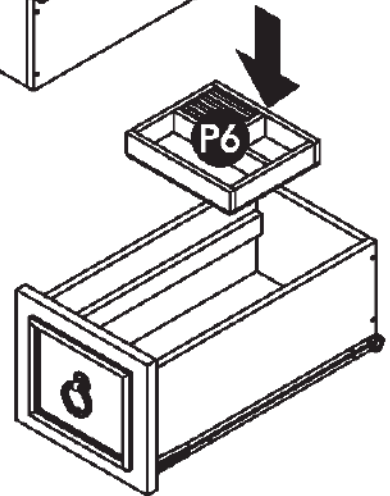

Note: Drawer assembly is not complete until 3/4" Flat Head Screws are used in a later step.

### Part List

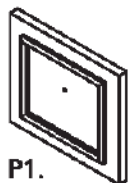

P1.  
Drawer Front  
2 pcs.



P2.  
Drawer Back  
2 pcs.

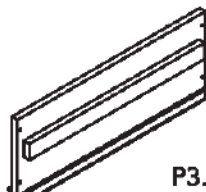

P3.  
Drawer Side  
2 pcs.

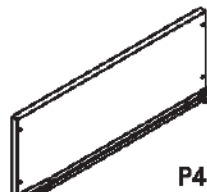

P4.  
Drawer Side  
2 pcs.

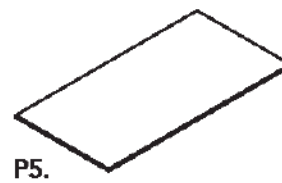

P5.  
Drawer Bottom  
2 pcs.

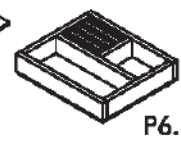

P6.  
Jewelry Box  
2 pcs.



# Drawer (Q)

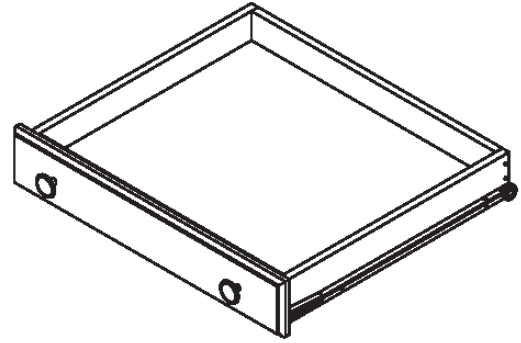

## STEP 16

Attach Drawer Sides (Q3), (Q4) and Drawer Support (Q6) to Drawer Back (Q2) with 1 1/4" Flat Head Screws.

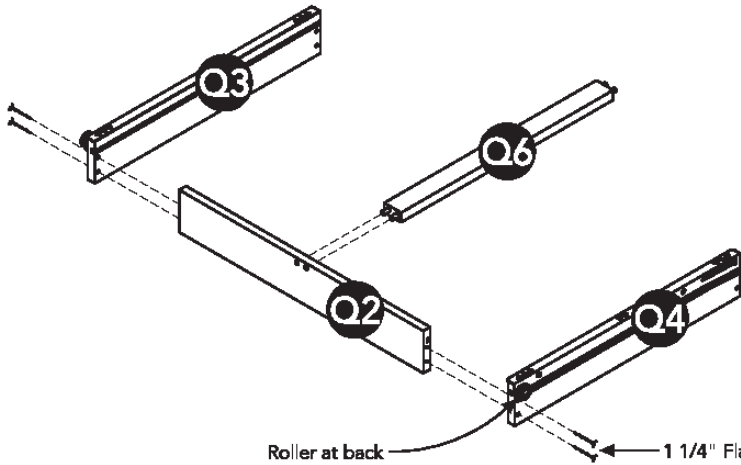

Roller at back

1 1/4" Flat Head Screw

## STEP 17

Insert Drawer Bottom (Q5) into groove.

Attach Drawer Front (Q1) to unit with 1 1/4" Flat Head Screws.

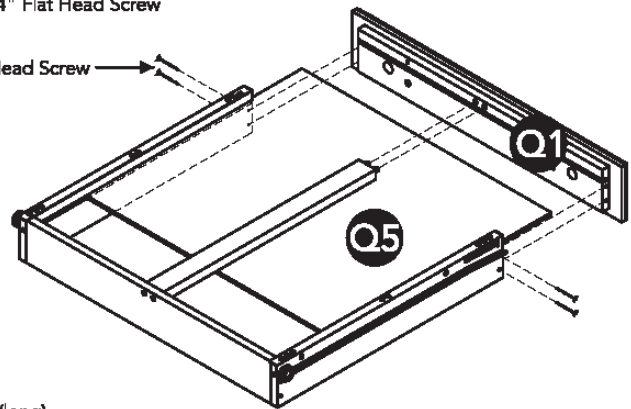

1 1/4" Flat Head Screw

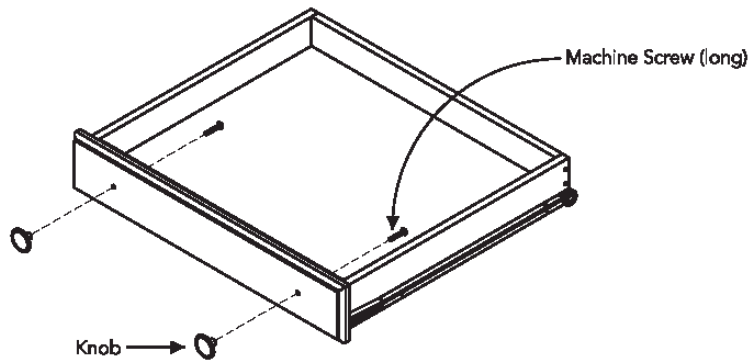

Machine Screw (long)

Knob

## STEP 18

Attach Knobs with Machine Screws (long).

Note: Drawer assembly is not complete until 3/4" Flat Head Screws are used in a later step.

### Part List

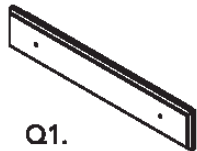

Q1.  
Drawer Front  
1 pc.



Q2.  
Drawer Back  
1 pc.



Q3.  
Drawer Side  
1 pc.

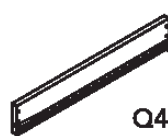

Q4.  
Drawer Side  
1 pc.

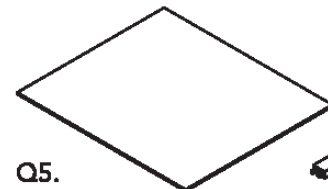

Q5.  
Drawer Bottom  
1 pc.

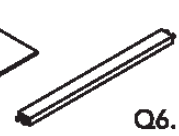

Q6.  
Drawer Support  
1 pc.

## STEP 19

For Drawers (P) loosen slightly upper center screw and uninstall lower center screw.

For Drawer (Q) loosen slightly screws pre-installed on back of drawer front.

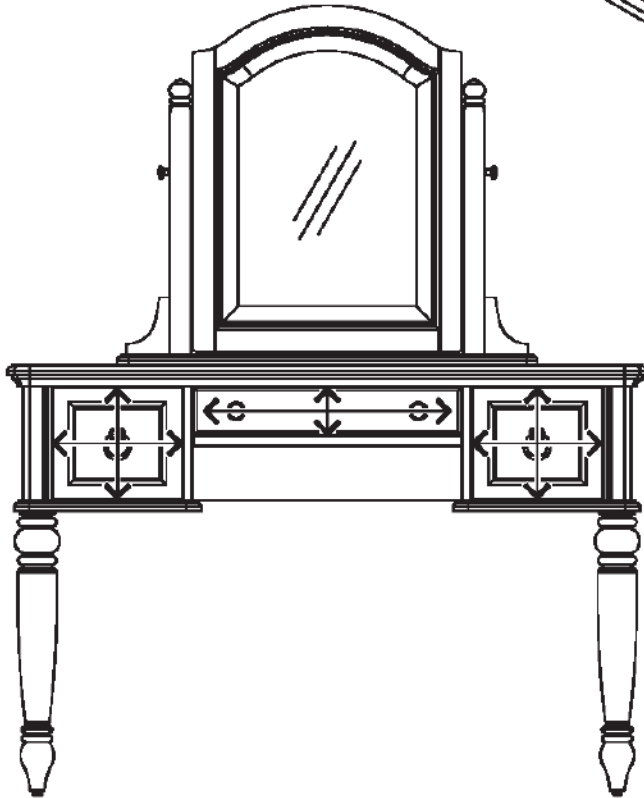
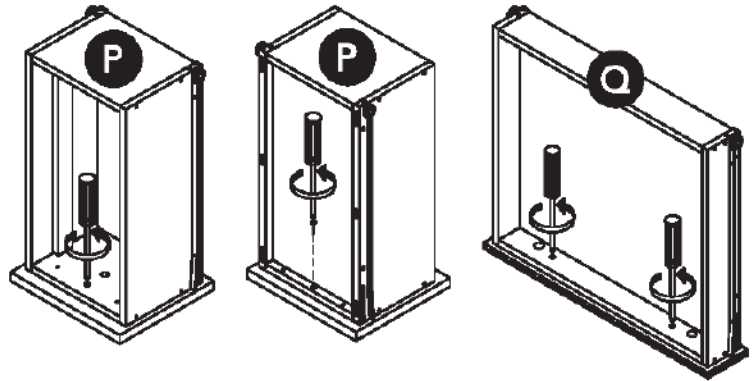

## STEP 20

Insert drawers into unit, then adjust drawer front panels left or right and up or down until drawer gaps look proportional.

## STEP 21

Pull each drawer open slowly and re-tighten screws from Step 18.

Make sure drawer front panels do not move and lock drawer front panels into position with 3/4" Flat Head Screws.

Note: These 3/4" Flat Head Screws must be installed to complete the drawer assembly.

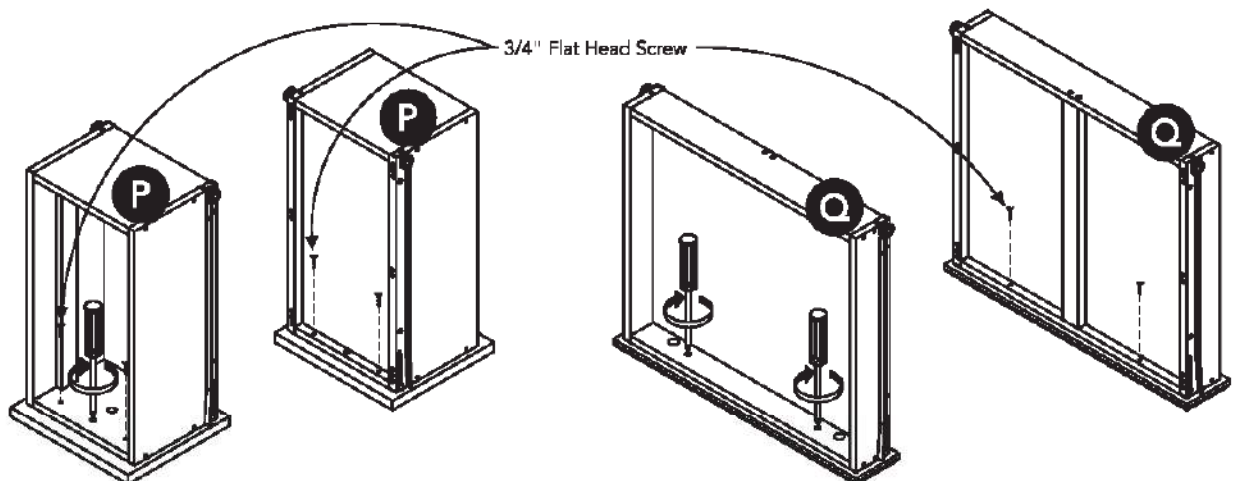

STEP 22

Slide Drawers (P) and (Q) into position.

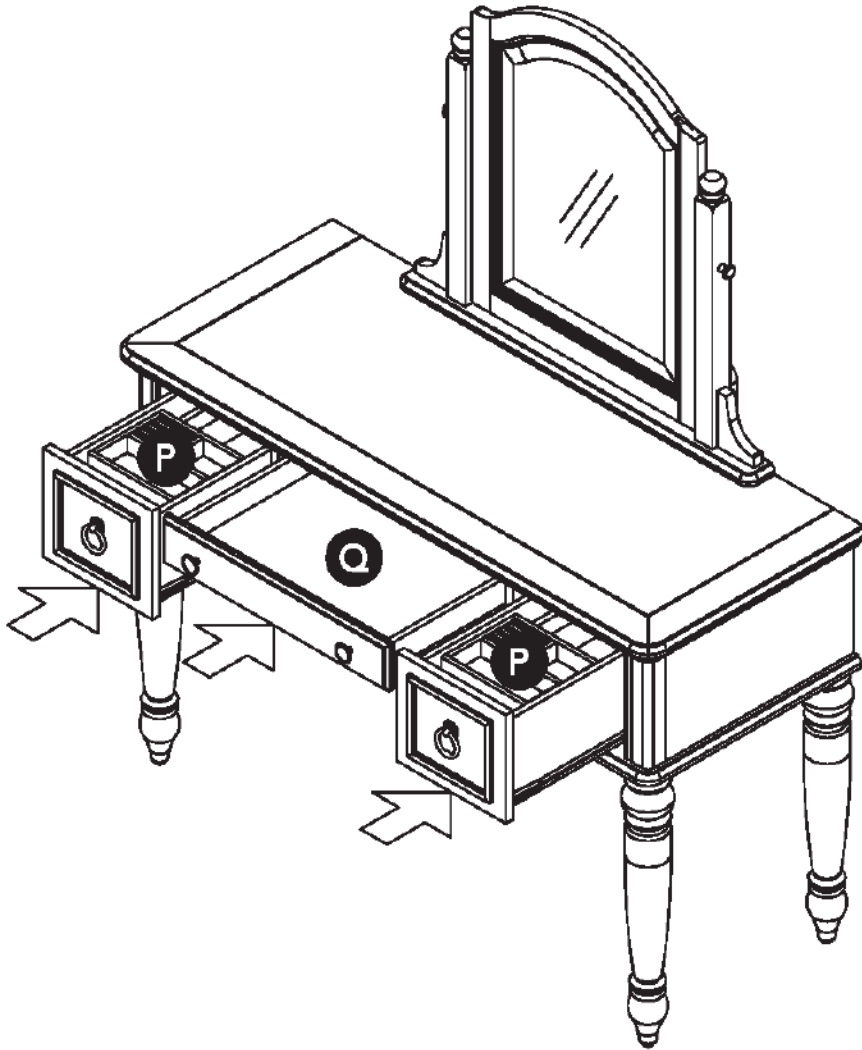

# CARE INSTRUCTIONS

## NEVER

allow liquids to remain on furniture.  
Absorption causes parts to warp  
and split and finishes to delaminate.

## NEVER

use glass cleaners on  
finished furniture. Ammonia  
chemically attacks the finish.



Do not use power tools  
above 8 volts to assemble.

**PREVENT  
CRACKING**



Do not place  
in direct sunlight.

**PREVENT  
FADING**



Do not write  
directly on surface.

**PREVENT  
MARKING**



Do not place hot  
objects on surface.

**PREVENT  
FINISH DAMAGE**



Do not use rubber  
based placemats.

**PREVENT  
DISCOLORING**



Do not use commercial  
waxes and polishes.

**PREVENT  
YELLOWING**

## CLEAN

with a soft cloth moistened  
in lukewarm soap and water.  
Buff with a dry clean cloth.



Home Styles will provide replacements free of charge for missing or damaged hardware or parts within 30 days of purchase. Digital images of the defective parts may be required. If the product was not purchased from an authorized retail affiliate, Home Styles is under no obligation to provide replacement parts. Parts are not available for fully assembled items nor are parts available for sale. Replacements for missing or damaged hardware or parts may be requested at: