

# C R O S L E Y

## F U R N I T U R E

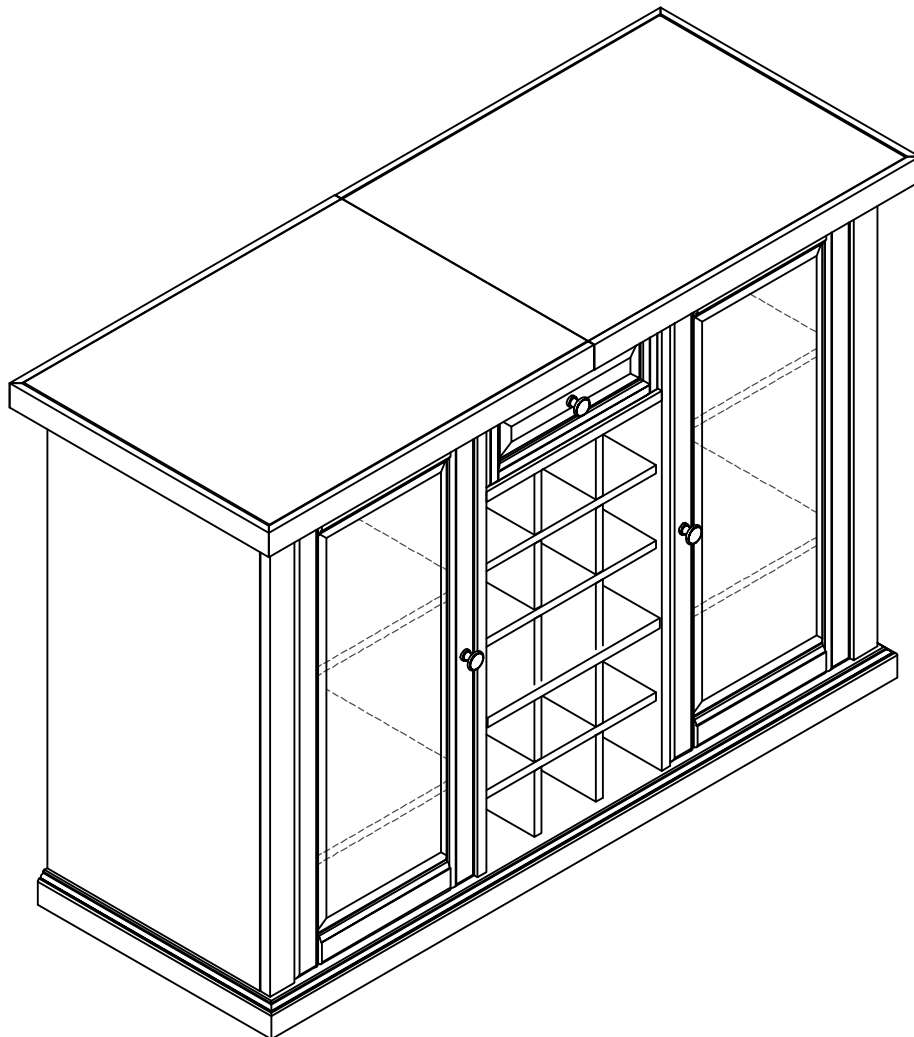



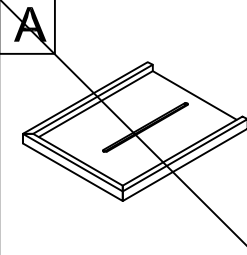
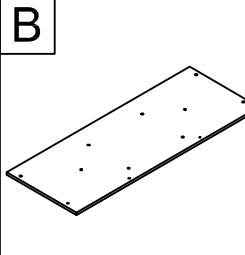
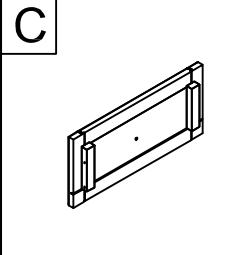
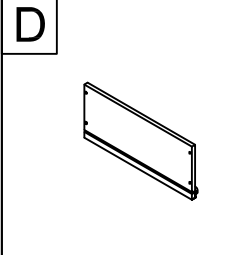
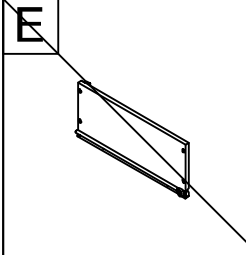
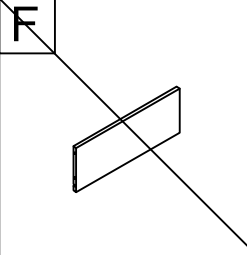
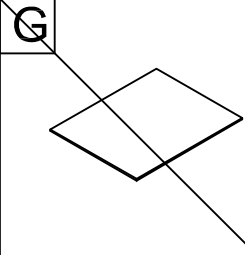
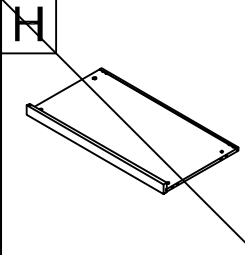
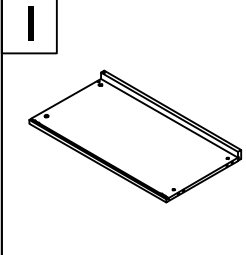
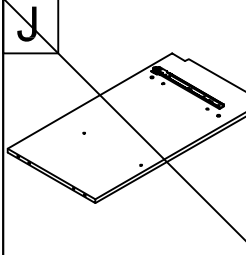
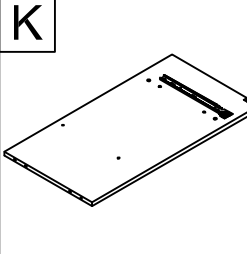
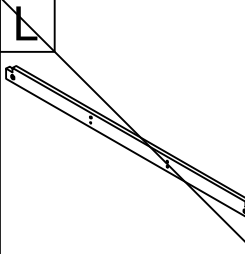
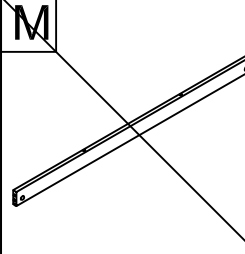
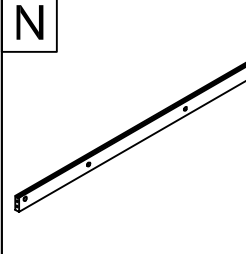
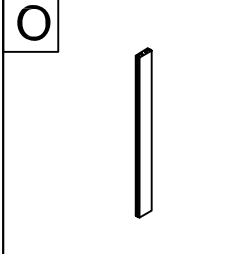
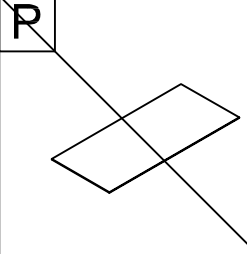
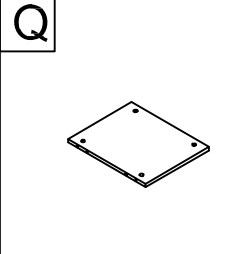
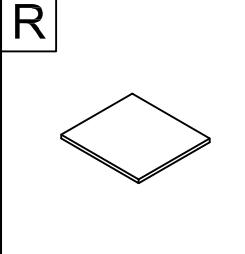
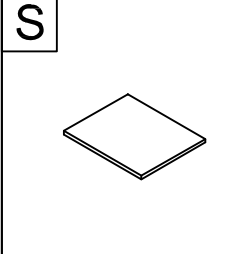
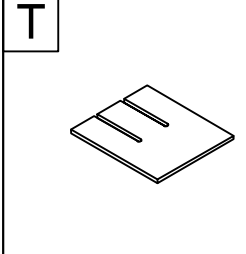
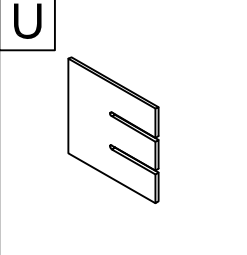
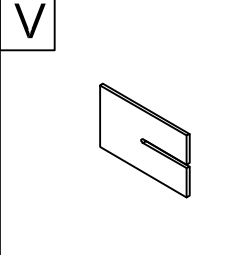
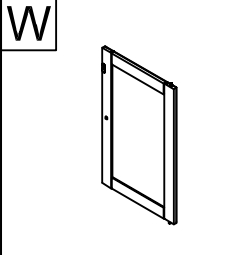
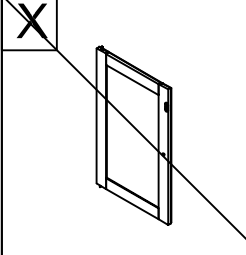
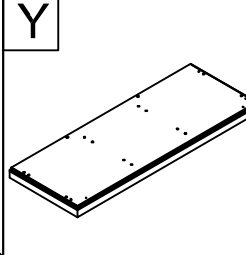

BAR CABINET WITH SLIDING TOP  
CF4002

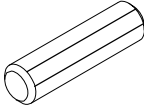
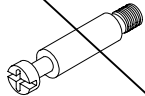

# PART LIST

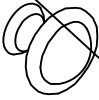
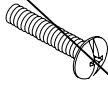
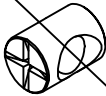
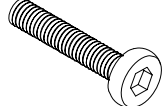
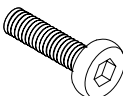
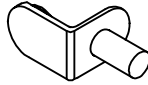
				
Pull-Out Top 2 PCS	Top 1 PC	Drawer Front Panel 1 PC	Drawer Left Side Panel 1PC	Drawer Right Side Panel 1 PC
				
Drawer Back Panel 1 PC	Drawer Bottom Panel 1 PC	Left Side Panel 1 PC	Right Side Panel 1 PC	Left Partition Panel 1 PC
				
Right Partition Panel 1 PC	Front Top Rail 1 PC	Back Top Rail 1 PC	Back Bottom Rail 1 PC	Back Partition Rail 2 PCS
				
Back Panel 3 PCS	Wood Shelf 1 PC	Adjustable Shelf 4 PCS	Wine Holder Adjustable Shelf 1 PC	Wine Holder Shelf 3 PCS
				
Large Wine Holder Wood Stand 2 PCS	Short Wine Holder Wood Stand 2 PCS	Left Door 1 PC	Right Door 1 PC	Base 1 PC

# HARDWARE LIST

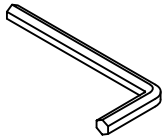
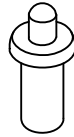
<p><b>1</b></p> 	<p><b>2</b></p> 	<p><b>3</b></p> 	<p><b>4</b></p> 	<p><b>5</b></p>  <p>7/8" * <math>\varnothing</math>5/32" * D9</p>
<p>Wood Dowel 30 PCS</p>	<p>Cam Bolt 20 PCS</p>	<p>Cam Lock 20 PCS</p>	<p>Knob 3 PCS</p>	<p>Round Head Bolt 3 PCS</p>
<p><b>6</b></p> 	<p><b>7</b></p>  <p>2" * <math>\varnothing</math>1/4" * D11</p>	<p><b>8</b></p>  <p>7/8" * <math>\varnothing</math>1/4" * D11</p>	<p><b>9</b></p> 	<p><b>10</b></p> 
<p>Barrel Nut 8 PCS</p>	<p>Long Hex Socket Head Bolt 8 PCS</p>	<p>Short Hex Socket Head Bolt 2 PCS</p>	<p>Shelf Holder 20 PCS</p>	<p>Magnet 2 PCS</p>
<p><b>11</b></p>  <p>12mm * <math>\varnothing</math>3 * D6mm</p>	<p><b>12</b></p>  <p>1" * <math>\varnothing</math>4 * D8</p>	<p><b>13</b></p>  <p>1-1/4" * <math>\varnothing</math>4 * D8</p>	<p><b>14</b></p> 	<p><b>15</b></p> 
<p>Round Head Screw 4 PCS</p>	<p>Short Flat Head Screw 8 PCS</p>	<p>Long Flat Head Screw 2 PCS</p>	<p>Flat Washer 2 PCS</p>	<p>Allen Key 1 PC</p>
<p><b>16</b></p>  <p>Pin Hinge (Spare Parts) 4 PCS</p>				

Tools needed: Allen Key (Part #15) (included)  
Phillips Head Screw Driver (Not included)

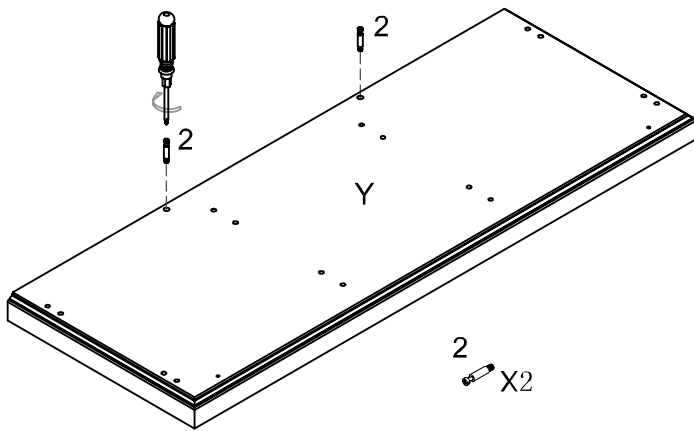
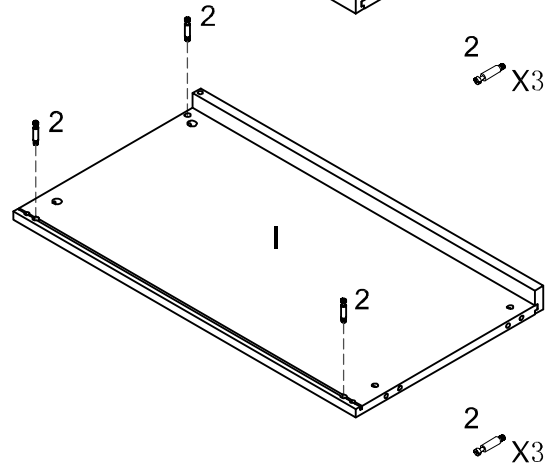
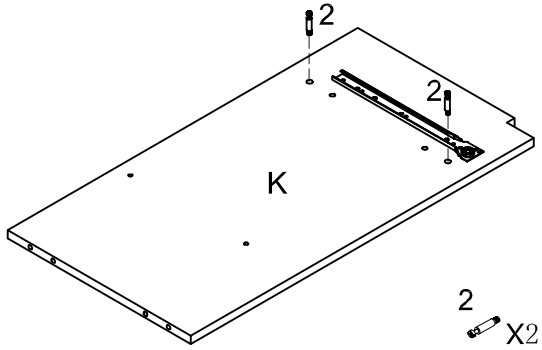
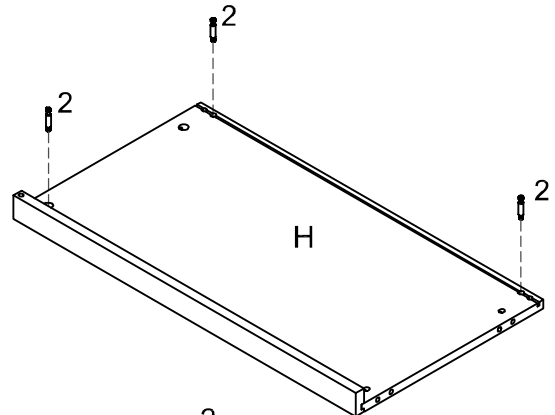
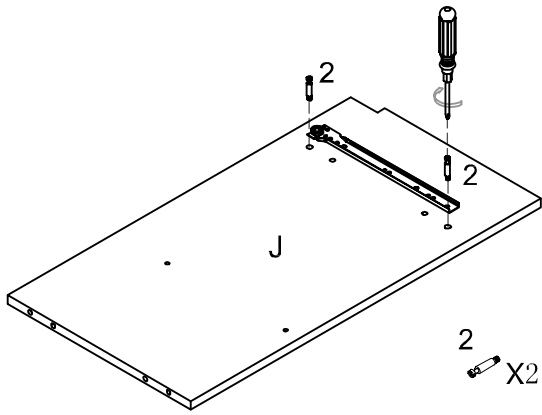

Step 1  
 Insert Cam Bolts (Part #2) into pre-drilled holes of parts B, H, I, J, K & Y using Phillips head screw driver as shown.  
**DO NOT OVERTIGHTEN.**

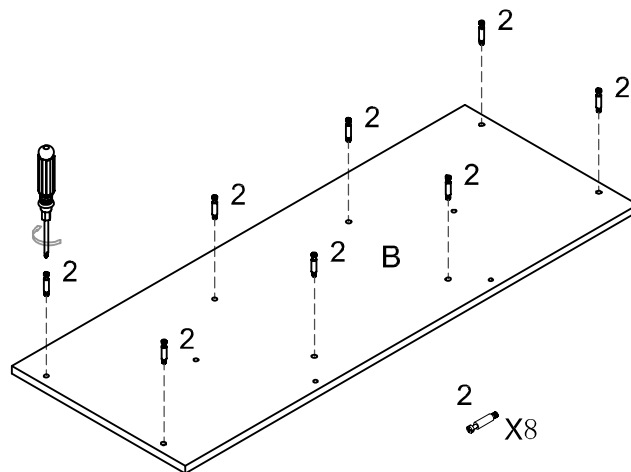

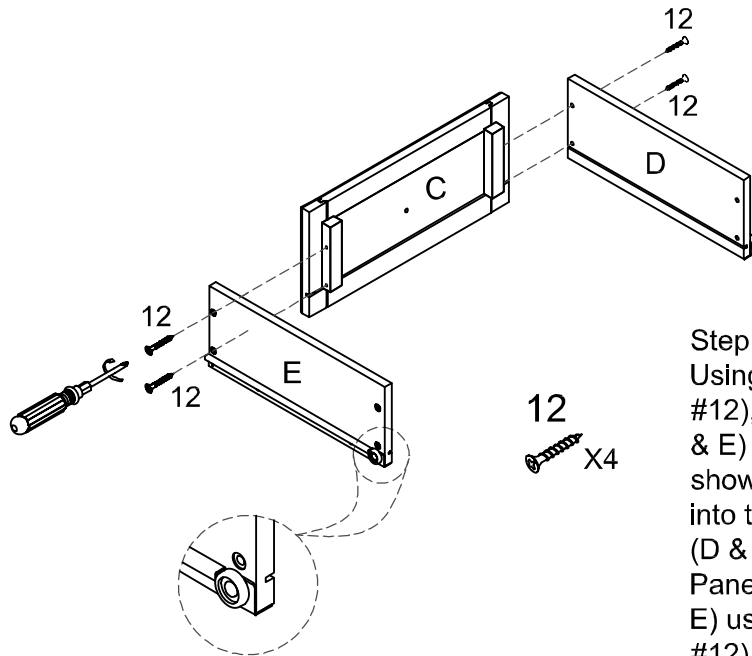

**Step 2**

Using Short Flat Head Screws (Part #12), attach the Drawer Side Panels (D & E) and the Drawer Front Panel (C) as shown. Insert Drawer Bottom Panel (G) into the grooves of Drawer Side Panels (D & E) as shown. Attach Drawer Back Panel (F) to Drawer Side Panels (D & E) using Short Flat Head Screws (Part #12) as shown. Attach Knob (Part #4) to Drawer Front Panel (C) using Round Head Bolt (Part #5).

**NOTE** - Be sure that the roller wheel on Panels (D & E) are on the outside and opposite the drawer front.

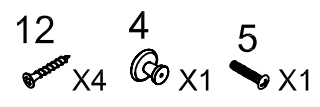
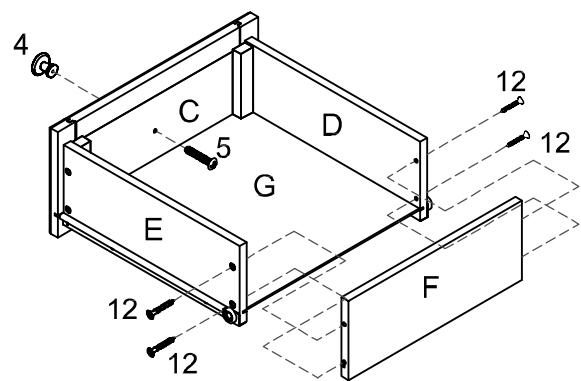
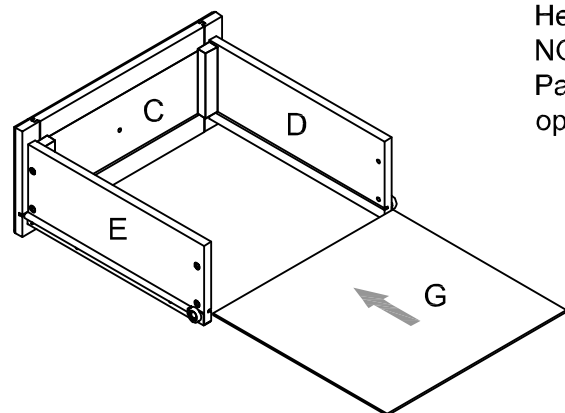

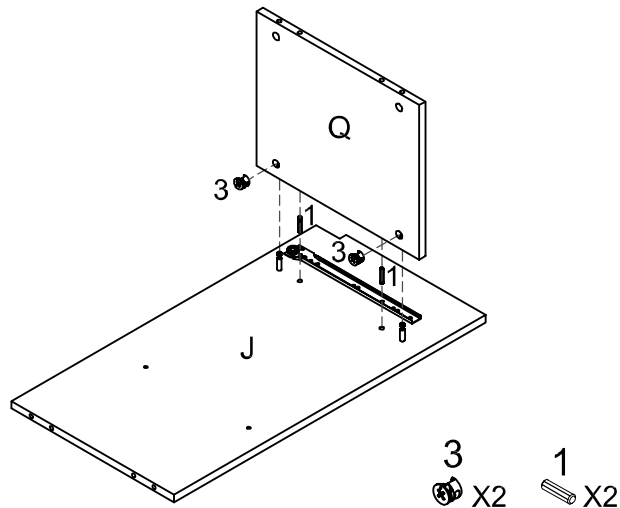
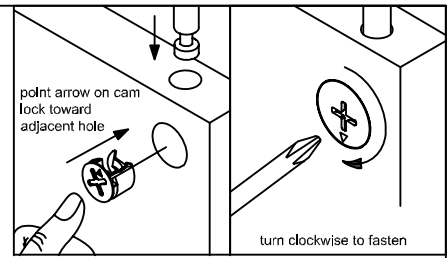

**Step 3**  
With Left Partition Panel (J) flat on the floor (fixed drawer guide facing up), attach Wood Shelf (Q) using Wood Dowels (Part #1) and Cam Locks (Part #3) as shown.

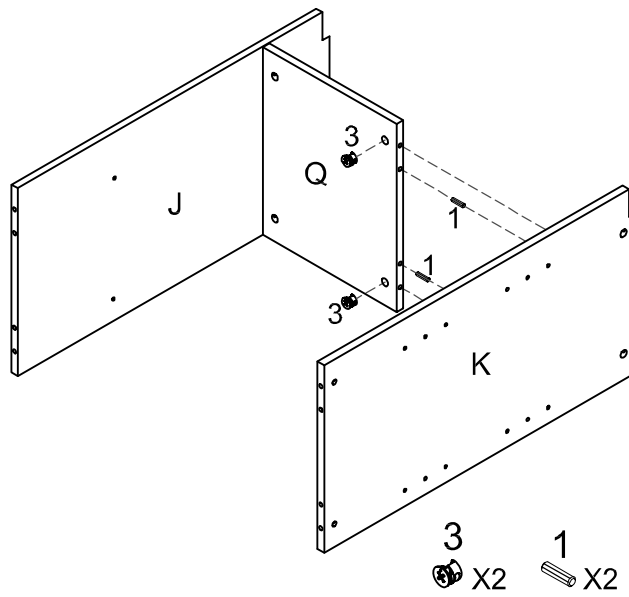

**Step 4**  
Turn assembled parts (J & Q) on their side. Attach Right Partition Panel (K) using Wood Dowels (Part #1) and Cam Locks (Part #3) as shown.

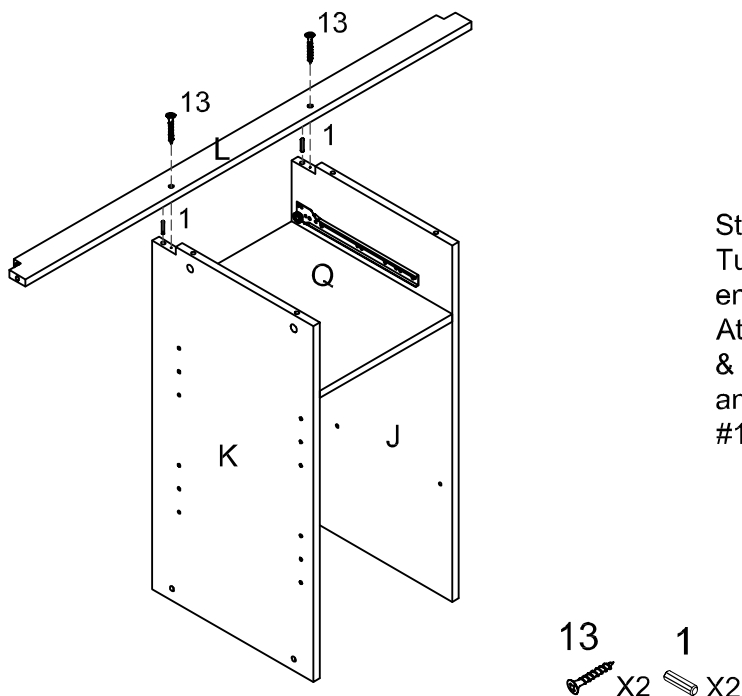

**Step 5**  
Turn assembled parts (J, K & Q) on end with cutout notches facing up. Attach Front Top Rail (L) to Panels (J & K) with Wood Dowels (Part #1) and Long Flat Head Screws (Part #13) as shown.

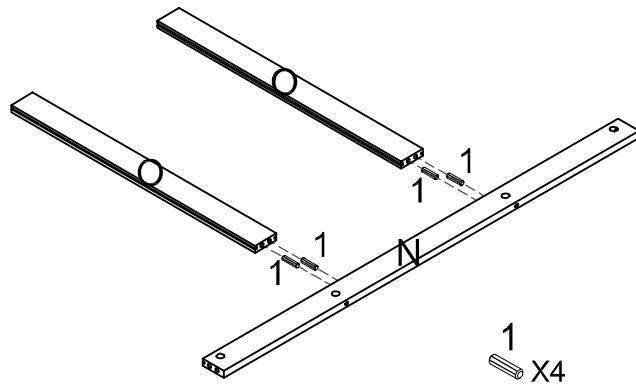

**Step 6**  
 With Back Bottom Rail (N) on a flat surface, attach Back Partition Rails (O) using Wood Dowels (Part #1).

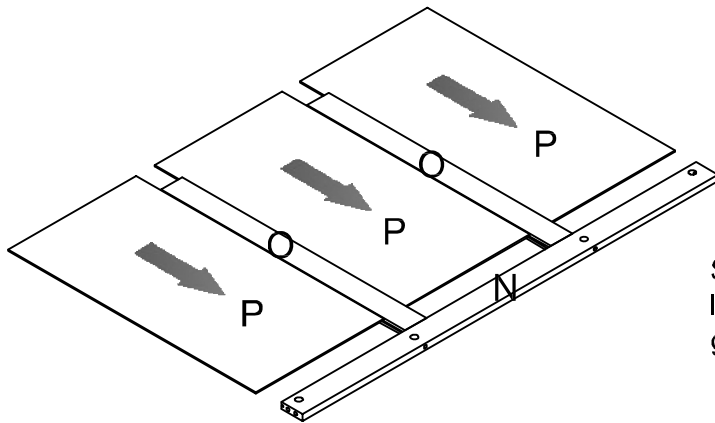

**Step 7**  
 Insert Back Panels (P) into the grooves of Rails (N & O).

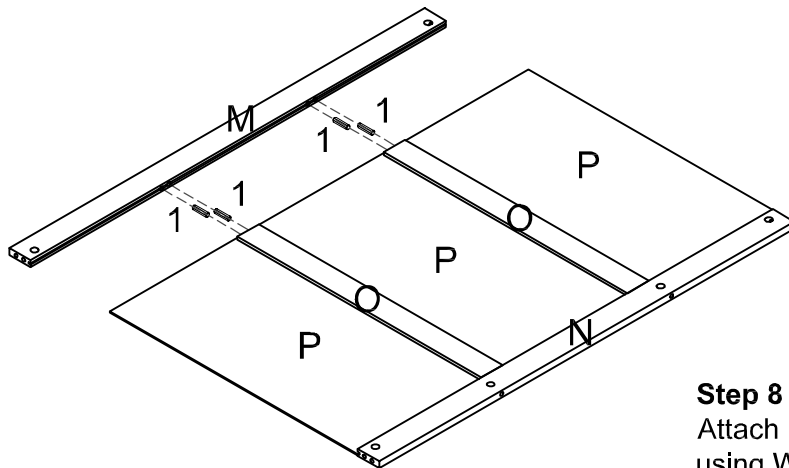

**Step 8**  
 Attach Back Top Rail (M) to Rails (O) using Wood Dowels (Part #1) as shown.  
 NOTE - Be sure that Back Panels (P) are completely inserted into the grooves of parts M, N & O.

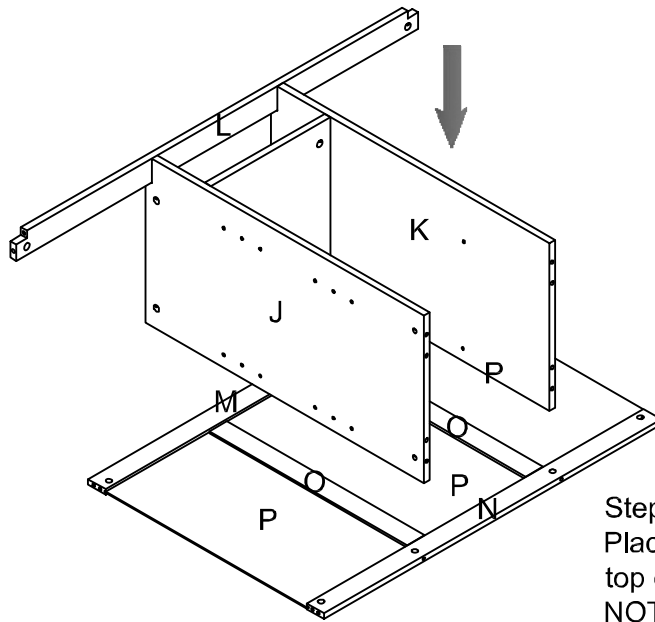
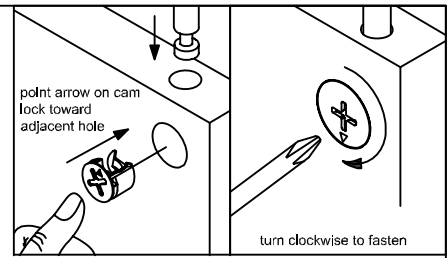

**Step 9**  
Place assembled parts J, K & L on top of assembled parts M, N, O & P.  
NOTE - Panels J & K should be directly on top of Rails (O).

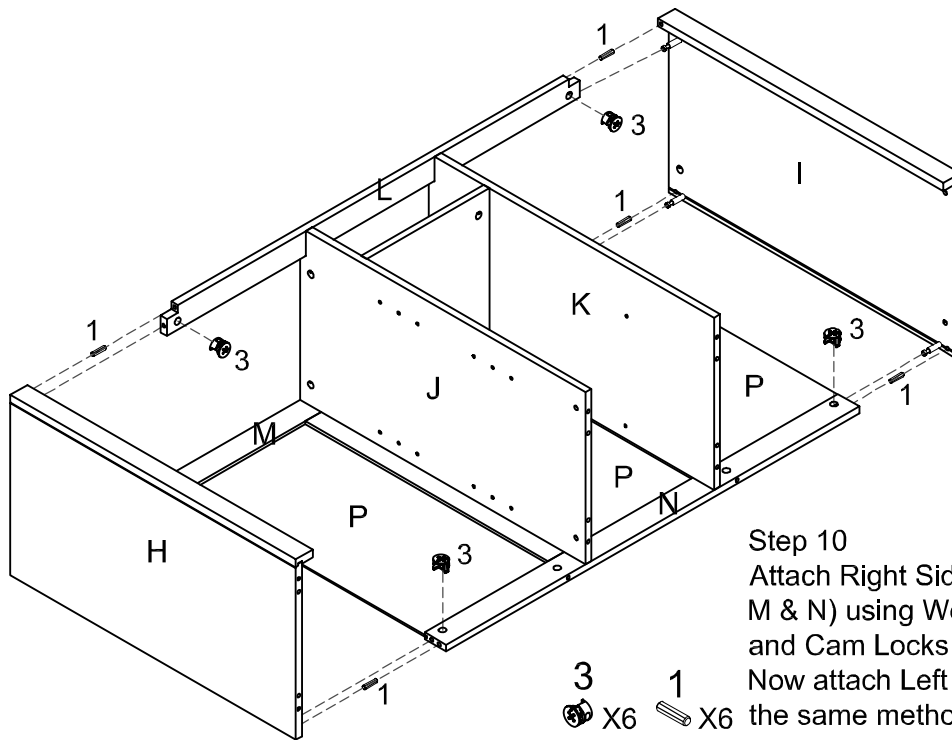

**Step 10**  
Attach Right Side Panel (I) to Rails (L, M & N) using Wood Dowels (Part #1) and Cam Locks (Part #3) as shown. Now attach Left Side Panel (H) using the same method as Panel (I).

3 X6    1 X6



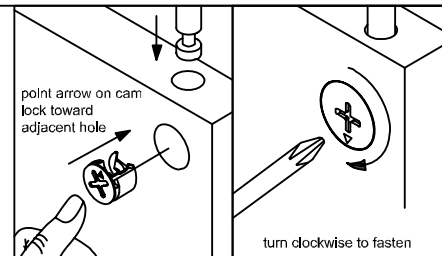
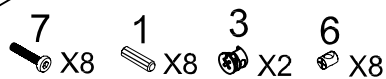
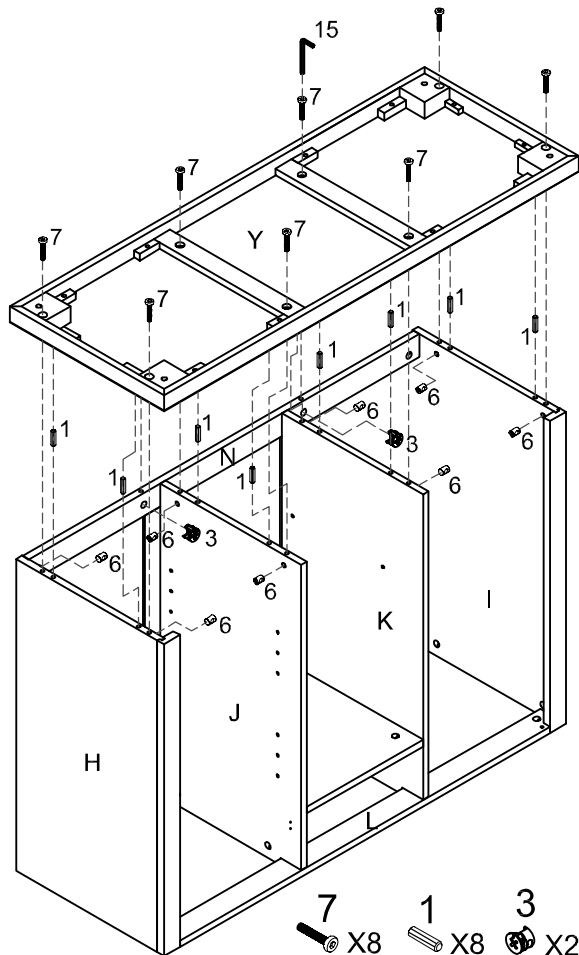

### Step 11

Turn cabinet over with Rail (L) on a flat surface. Attach Base (Y) using Wood Dowels (Part #1) and Long Hex Socket Head Bolts (Part #7) as shown. Attach Legs (packaged separately) using Hex Socket Head Bolts & Wood Dowels (as shown in instruction manual included with legs). Carefully turn cabinet over so that legs are now flat on the floor.

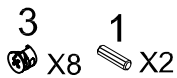
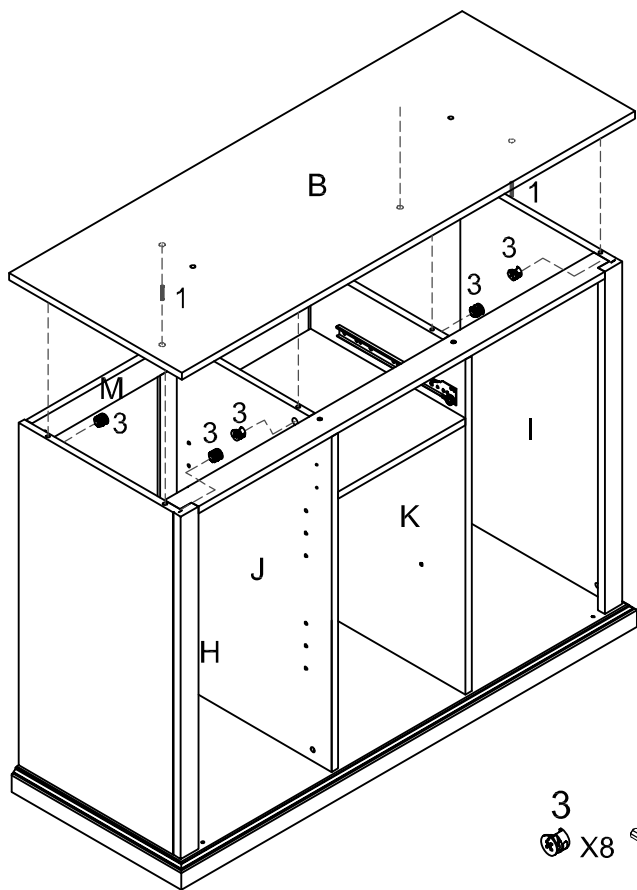

### Step 12

Attach Top (B) using Wood Dowels (Part #1) and Cam Locks (Part #3) as shown.

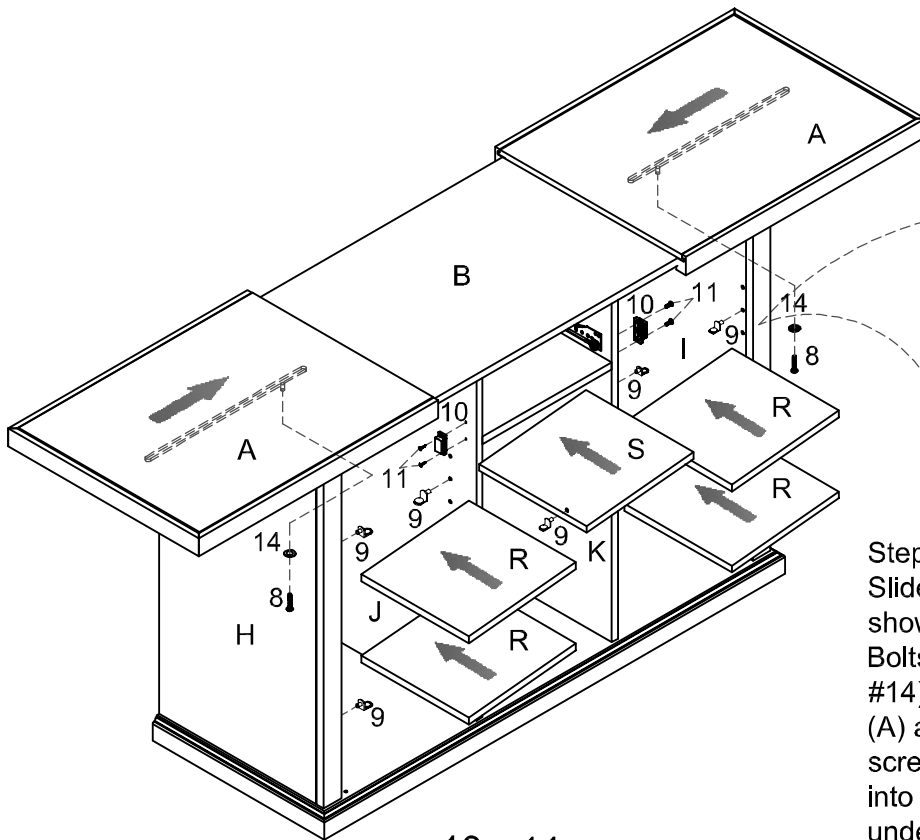

### Step 13

Slide Pull-Out Tops (A) onto Top (B) as shown. Insert Short Hex Socket Head Bolts (Part #8) into Flat Washers (Part #14). Making sure that Pull-Out Tops (A) are completely pushed together, screw Hex Socket Head Bolts (Part #8) into the left & right side holes on the underside of Top (B). **Note- These bolts will act as a "stop" to prevent Pull-Out Tops (A) from sliding off completely.** Now attach Magnets (Part #10) to the pre-drilled holes in Panels J & K using Round Head Screws (Part #11). Insert Shelf Holders (Part #9) into the cabinet at desired positions and add Adjustable Shelves (R & S).

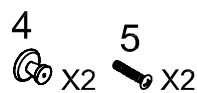
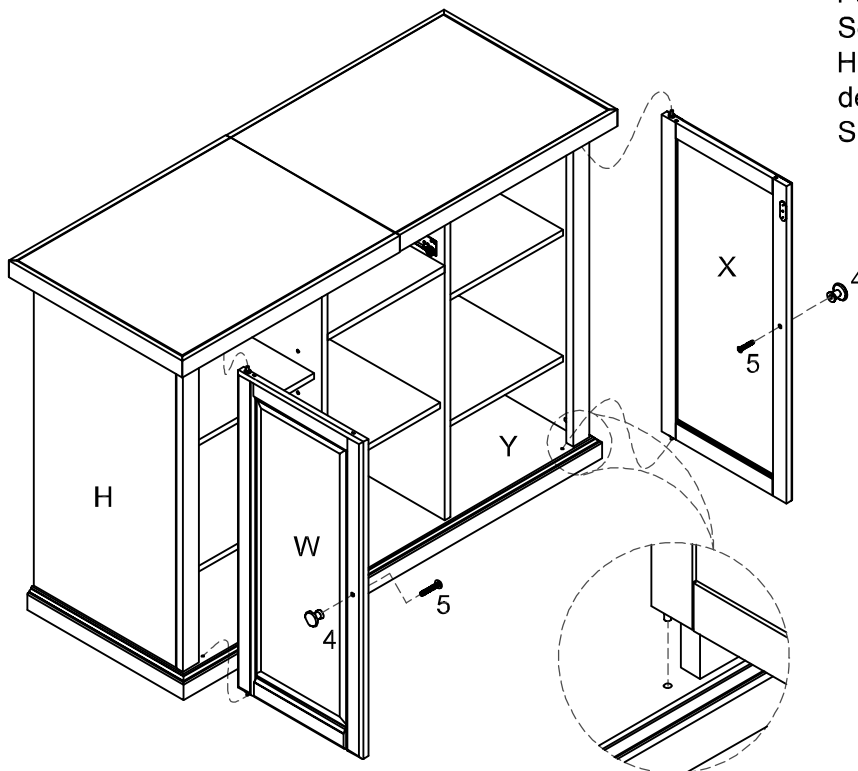

### Step 14

Attach Doors (W & X) to the cabinet by placing bottom Pin Hinge into the pre-drilled holes at the bottom & depressing the top spring loaded Pin Hinge to fit the doors into place. **Note - Be sure Pin Hinges have fully extended into the pre-drilled holes to secure the doors into place.**

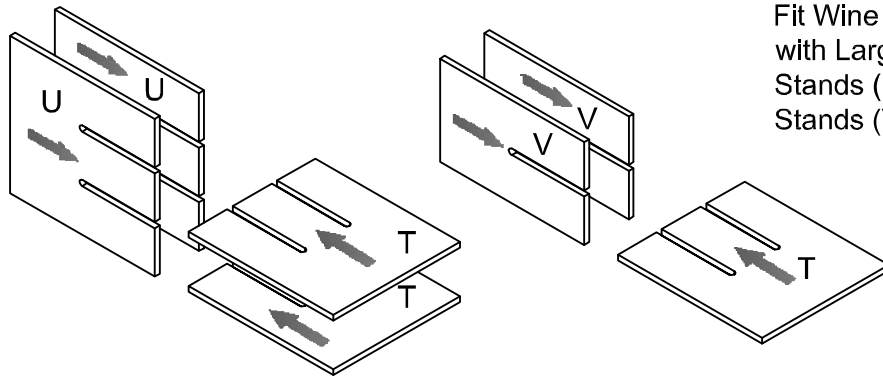

Step 15  
Fit Wine Holder Shelves (T) together with Large Wine Holder Wood Stands (U) and Short Wine Holder Stands (V) as shown.

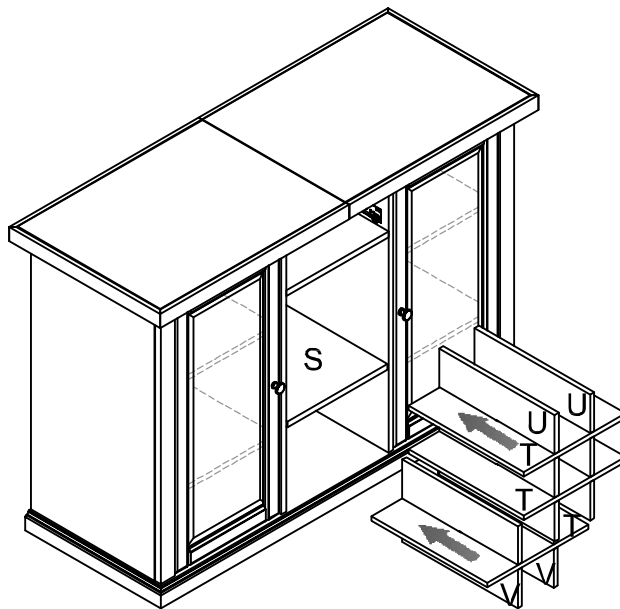

Step 16  
Insert assembled parts T & U into the cabinet above Shelf (S). Insert assembled parts (T & V) into the cabinet below Shelf (S).  
**Note - Shelf (S) is adjustable. Be sure that it is in the proper position to insert the wine holders.**

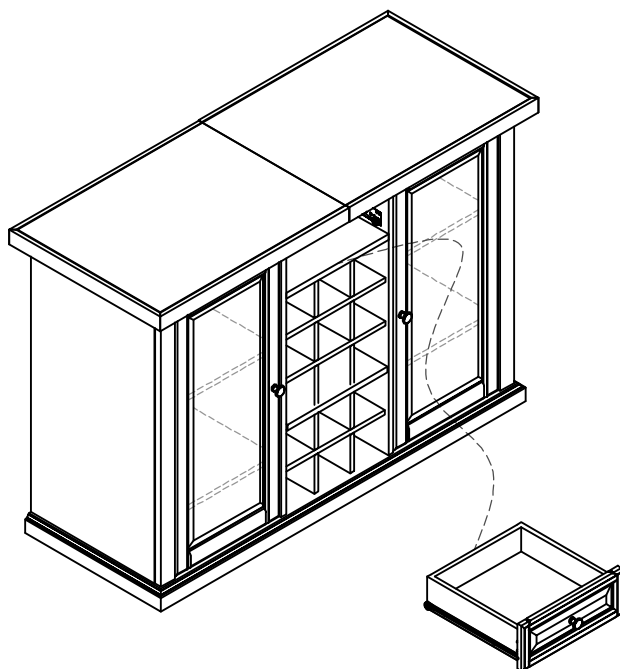

Step 17  
Insert the assembled drawer as shown.

**Congratulations! You are finished.**