

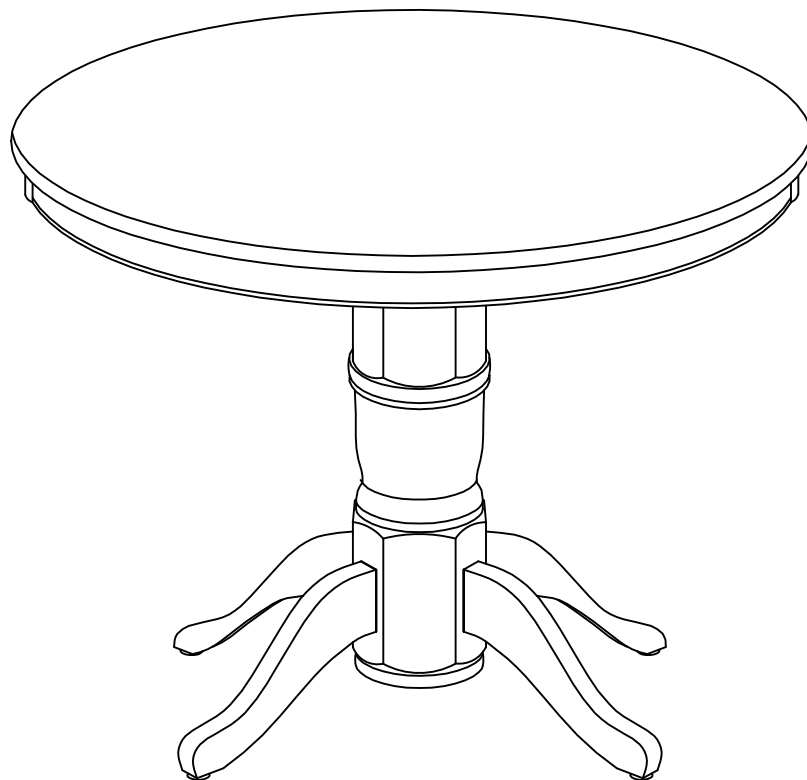

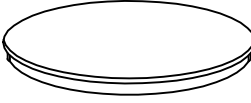

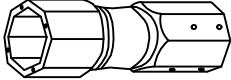

**Round Dining Table
CF2003**



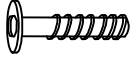
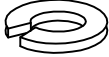
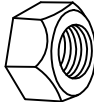

PART LIST

<p>A</p>  <p>With Apron</p>	<p>B</p> 	<p>C</p> 	<p>D</p> 
<p>Top 1 PC</p>	<p>Pedestal Post 1 PC</p>	<p>Leg 4 PCS</p>	<p>Plate 1 PC</p>

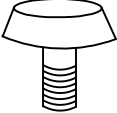
HARDWARE LIST

<p>#1</p>  <p>M6 x 40mm</p>	<p>#2</p> 	<p>#3</p>  <p>M8</p>	<p>#4</p> 	<p>#5</p> 
<p>Bolt 8 PCS (Extra 1)</p>	<p>Spring Washer 4 PCS (Extra 1)</p>	<p>Hex Nut 8 PCS (Extra 1)</p>	<p>Flat Washer 12 PCS (Extra 1)</p>	<p>Adjustable Leveler 4 PCS (Extra 1)</p>

<p>#6</p>  <p>M4</p>	<p>#7</p>  <p>12.8mm</p>
<p>Allen Wrench 1 PC</p>	<p>Wrench 1 PC</p>

Step 3 . Carefully lay top (part A) upside down on a flat, soft surface, such as carpet. Attach assembled unit (parts B, C & D) to top (part A) using bolts (part #1), spring washers (part #2), flat washers (part #4) and allen wrench (part #6). Install adjustable levelers (part #5) to legs (part C).

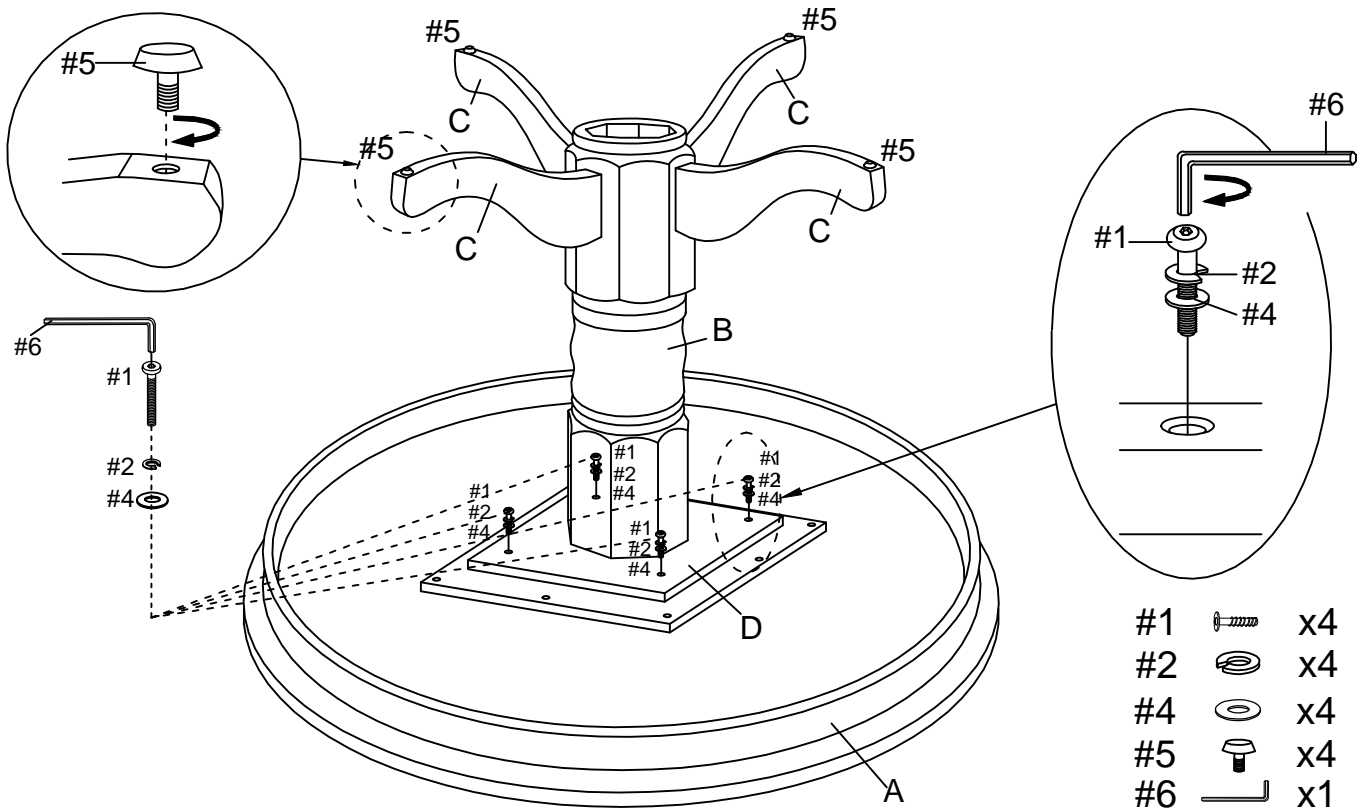

Step 4 . Carefully turn unit upright.

