

HINGE OPEN 180°
ISOMETRIC VIEW

3/16" DIA HOLE WITH
11/32" DIA x 82° C'SINK

9/64" DOOR CLEARANCE

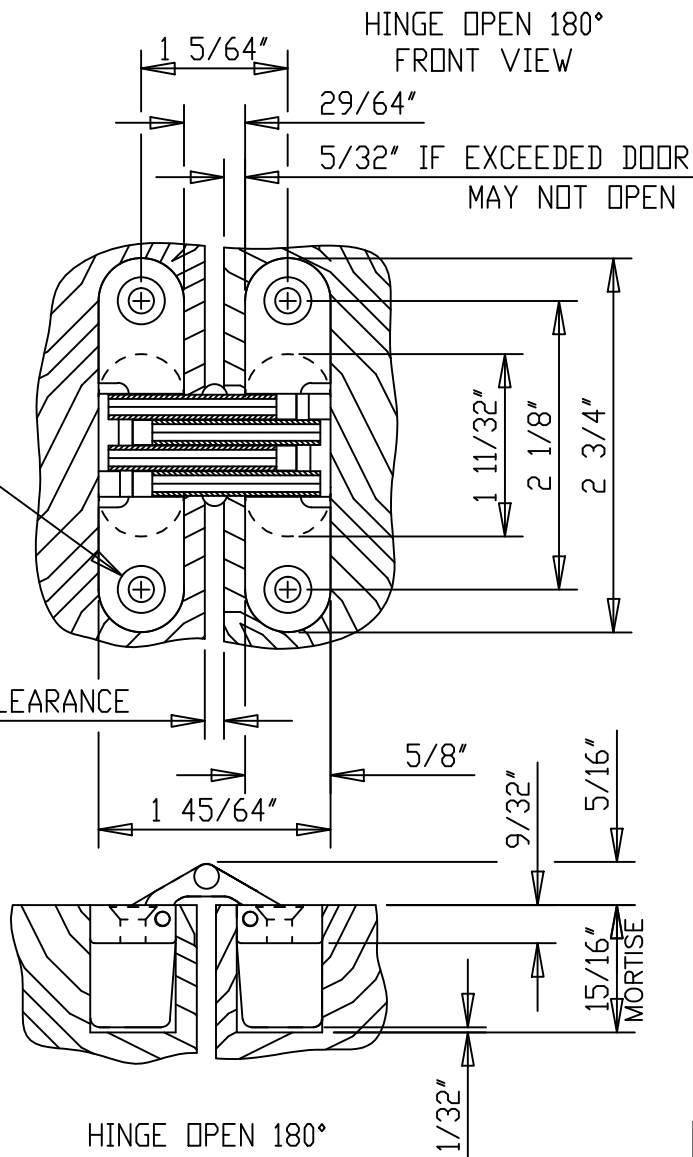

HINGE OPEN 180°
TOP VIEW CUT AWAY

HINGE CLOSED
FRONT VIEW CUT AWAY

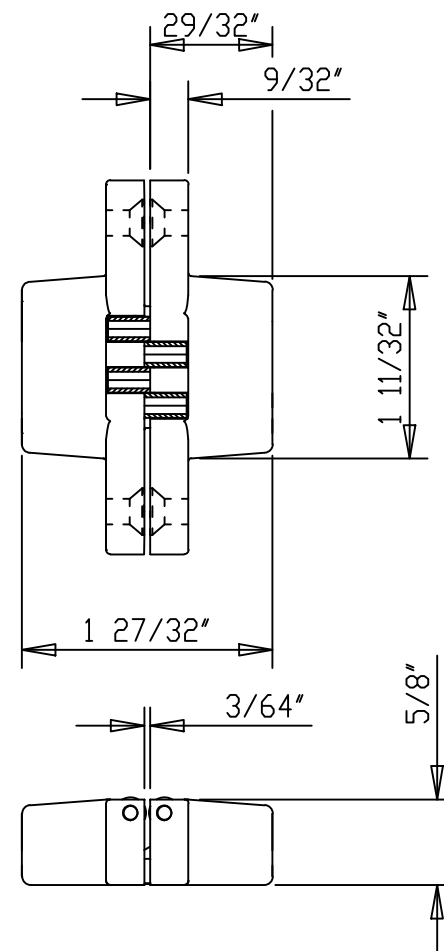

HINGE CLOSED
TOP VIEW CUT AWAY

SUPPLIED:
WOOD SCREW
#8 x 1-1/4"
SPECIAL ORDER:
MACH. SCREW
#8-32 x 5/8"

MIN. MATERIAL THICKNESS IS 1"
DO NOT SCALE DRAWING
ALL DIMENSIONS ARE IN INCH
DOOR CLEARANCE REDUCES TO 1/64" WHILE CLOSING
SEE DWG# 4477-C IF ADDING MATERIAL TO DOOR FACE AND/OR FRAME FACE

 Copyright 2008 Universal Industrial Products, Inc. One Coreway Drive Pioneer, Ohio 43554-0628	SCALE: 3/4 = 1
	DRAWN BY: LHH
HINGE TEMPLATE	DATE: 10/01/13
#208 8PSS INDUSTRIAL HINGE	DRAWING # 208