

HINGE OPEN 180°  
ISOMETRIC VIEW

.156" DIA WITH  
9/32" DIA x 82° C'SINK

7/64" DOOR CLEARANCE

SUPPLIED:  
WOOD SCREW  
#6 x 1"  
SPECIAL ORDER:  
MACH. SCREW  
#6-40 x 1/2"

HINGE OPEN 180°  
FRONT VIEW

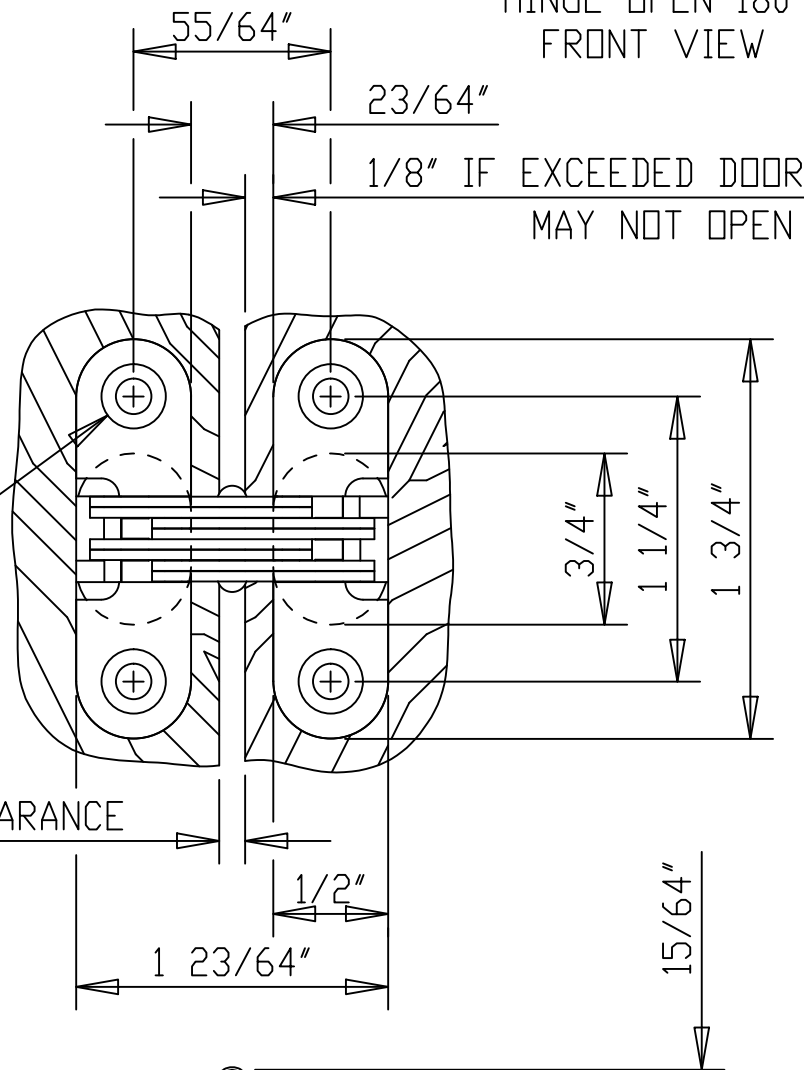

HINGE OPEN 180°  
TOP VIEW CUT AWAY

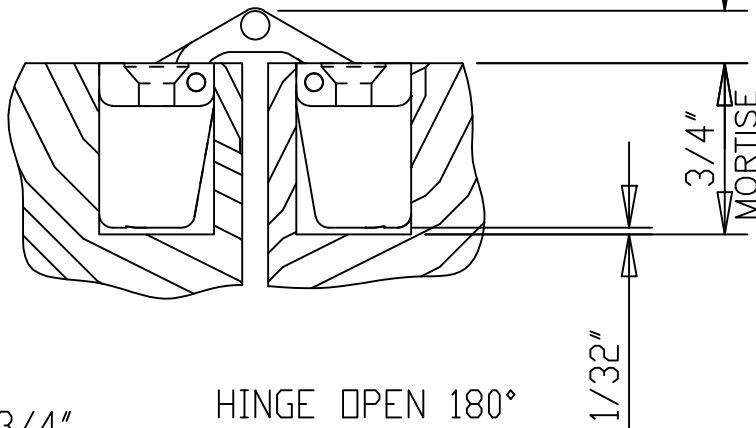

HINGE CLOSED  
FRONT VIEW CUT AWAY

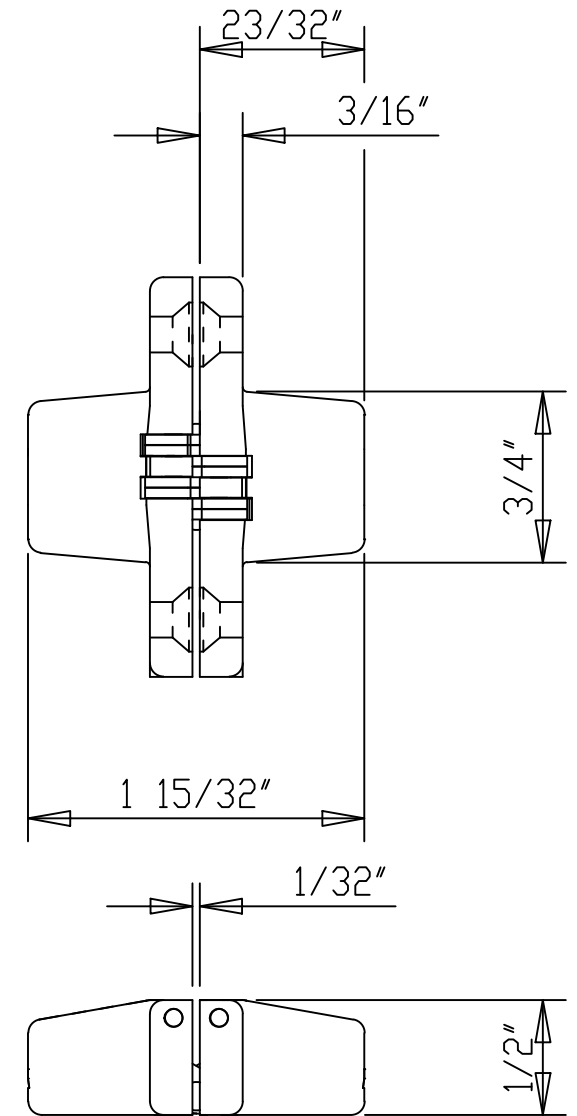

HINGE CLOSED  
TOP VIEW CUT AWAY

**UIIP** ©Copyright 2008  
Universal Industrial Products, Inc.  
One Coreway Drive

SCALE: 1 = 1

DRAWN BY: JHH

**●●kitchensource.com**

☎ 1.800.667.8721

MIN. MATERIAL THICKNESS IS 3/4"  
DO NOT SCALE DRAWING  
ALL DIMENSIONS ARE IN INCH  
DOOR CLEARANCE REDUCES TO 1/64" WHILE CLOSING  
SEE DWG# 4477-C IF ADDING MATERIAL TO DOOR FACE AND/OR FRAME FACE