

Installation Instructions for USE58-500 Series Synchronized Slides

Dura-Close[®] Synchronized Soft-close Undermount Slides with 2nd Gen. Clips



Learn more about our 2nd Generation undermount clips.
Scan QR to view product video.
<https://delivr.com/2wzv6>



Simplify bracket installation with HR-TOOL-RBINST.
Scan QR to view video.
<https://delivr.com/2yhj3>



Parts Included:

1 pair USE58-500 Series Dura-Close[®] Synchronized Soft-close Undermount Slides

Also Needed:

6 each #6 x 5/8" Flat Head Screws (Part # 6X580)
8 each #6 x 5/8" Pan Head Screws (Part # 6X2580)
1 pair Undermount Release Clips
1 pair Rear Mounting Brackets (Framed cabinetry only)

Required Tools:

Pencil
Screwdriver
Level
Tape Measure
Framing Square

Optional Tool:

Rear Slide Bracket Installation Tool
(See QR code above for a video with details)

Compatible Clips: See how to adjust 2nd Generation Undermount Clips on page 5



6-Way Adjustable, Zinc
USCLIP500-2-6WZ
(Replaces USCLIP500-6WZ)



4-Way Adjustable, Zinc
USCLIP500-2-4WZ
(Replaces USCLIP500-4WZ)



4-Way Adjustable
USCLIP500-2-4W
(Replaces USCLIP500-4W)

Construction & Assembly Specifications

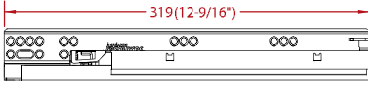
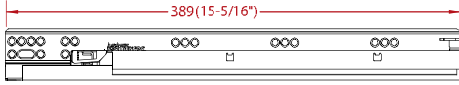
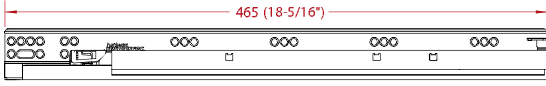
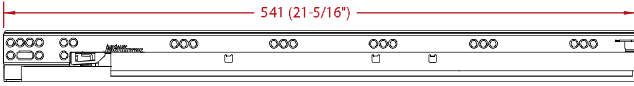
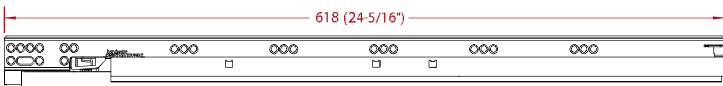
			FRAMELESS	FACE FRAME	
Slide Length	Total Cabinet Depth	Overall Drawer Length	Min Inside Cabinet Depth	Min Inside Cabinet Depth	Max Inside Cabinet Depth
			USE58-500-12 - (12") drawer		
12-9/16"	15"	12"	12-5/8"	12-7/8"	14"
319 mm	381 mm	305 mm	321 mm	326 mm	356 mm
			USE58-500-15 - (15") drawer		
15-5/16"	18"	15"	15-5/8"	15-7/8"	17"
389 mm	457 mm	381 mm	397 mm	403 mm	432 mm
			USE58-500-18 - (18") drawer		
18-5/16"	21"	18"	18-5/8"	18-7/8"	20"
465 mm	533 mm	457 mm	473 mm	479 mm	508 mm
			USE58-500-21 - (21") drawer		
21-5/16"	24"	21"	21-5/8"	21-7/8"	23"
541 mm	610 mm	533 mm	549 mm	555 mm	584 mm
			USE58-500-24 - (24") drawer		
24-5/16"	27"	24"	24-5/8"	24-7/8"	26"
618 mm	686 mm	610 mm	625 mm	632 mm	660 mm

CABINET AND DRAWER BOX DIMENSION VERIFICATION

- Ensure that the cabinet and drawer are both square by measuring the distance from the front of each side to the back of the opposite side of both the cabinet and drawer
- The maximum difference is 1/16"
- If the difference is greater than 1/16", the slide will not work correctly

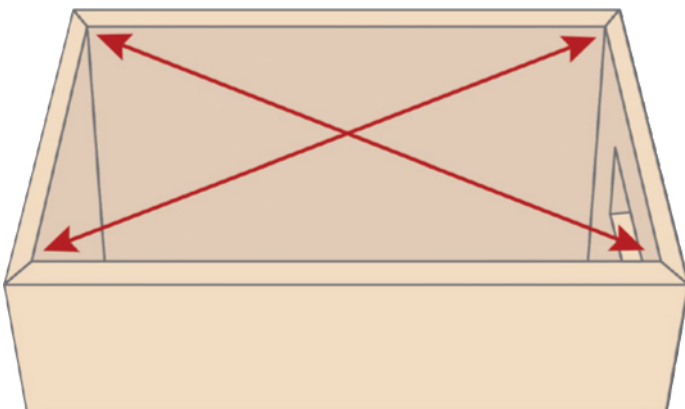

IMPORTANT: If the drawer box is not within the parameters below, the drawer slides will not function correctly

DRAWER BOX MINIMUM WIDTH

	USCLIP500-2-6WZ	USCLIP500-2-4WZ	USCLIP500-2-4W
5/8" (16 mm) material	8.25"	8.25"	8.25"
1/2" (13 mm) material	8"	8"	8"

MAXIMUM DRAWER HEIGHT = OPENING MINUS 19 MM (3/4")

OUTSIDE DRAWER WIDTH CALCULATIONS

FRONT VIEW OF THE DRAWER INSIDE THE CABINET

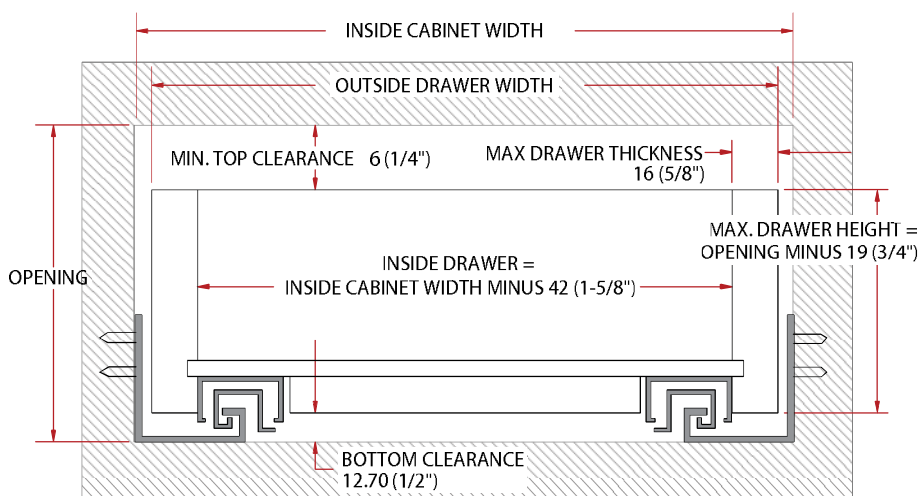

Drawer Side Thickness	Inside Cabinet Width Deduction
5/8" 16 mm	3/8" 10 mm
19/32" 15 mm	15/32" 12 mm
9/16" 14 mm	9/16" 14 mm
1/2" Hardwood 13 mm	5/8" 16 mm
1/2" Plywood 12 mm	13/16" 20 mm
15/32" 12 mm	23/32" 18 mm

FRONT HOLE PATTERN

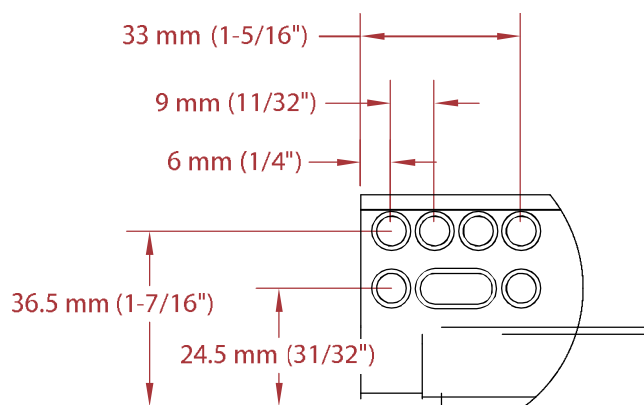

REAR NOTCH DIMENSIONS

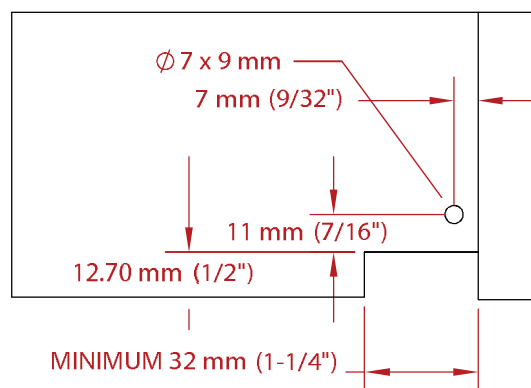

Installation Steps for Face-Framed Cabinetry

1. Choose rear mounting brackets (Sold separately)

NOTE: Installation screws not included with brackets.

- **USE-STEEL**
- **USE-ADJ**
- **USE-ADJ5** - Dowels plug into pre-drilled 8 mm system holes. Bracket provides wide range of lateral adjustment.

2. Install rear mounting brackets

NOTE: Simplify bracket installation with HR-TOOL-RBINST. Scan QR code on page 1 for a video walkthrough.

- On the front of the cabinet, measure the distance from the top of the cabinet to both the left and bottom corners of the cabinet opening
- Measure the distance from the inside of each side of the cabinet to both the left and right edge of the cabinet opening
- Align the outside bottom edges of both brackets using the measurements from steps 2a & 2b
- Fasten rear mounting brackets to the rear of the cabinet using 2 X #6 x 5/8" screws per bracket
 - For maximum adjustment during installation, use the slotted holes to fasten the screws loosely while making adjustments
 - Fasten screws loosely to allow the brackets to adjust when the drawer is first installed and fastened
 - Avoid stripping out screws by not overtightening

3. Install undermount slides

- Insert slides into cabinet opening and align the rear brackets with the slotted rear of each slide
- Align each slide to the corner of the cabinet opening (Recommended 1/8" setback for non-inset applications) and pre-drill each hole location using a 3/32" drill bit

For Inset drawer front applications:

Setback: 4 mm (5/32") + Drawer Front Thickness

- Fasten each member to the front rail of the cabinet using the front hole of the cabinet member and 1 X #6 x 1/2" flat head screw per side

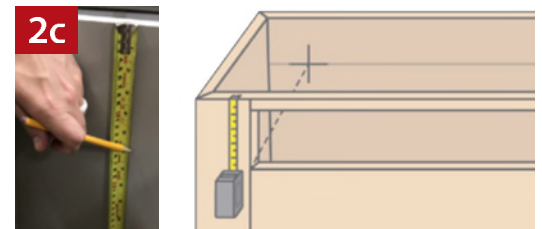
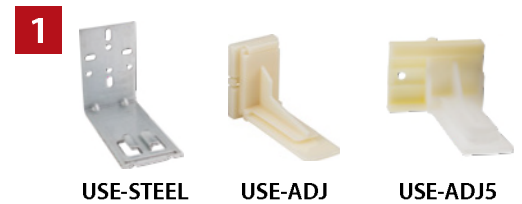

4. Install undermount clips

Insert slides into cabinet opening and align the rear brackets with the slotted rear of each slide

5. Install the drawer box

- a. Set the drawer box inside the cabinet
 - Ensure drawer box sits flush to the bottom of the drawer box inside each notch at the back of the drawer box
- b. Press the drawer in toward the rear of the cabinet until both side slides engage with both release clips
 - Listen for an audible click sound ensuring the drawer is locked in place
- c. Ensure the rear hooks are embedded within the rear hole of both sides of the drawer box

See how to remove drawer boxes on p. 6



How to Adjust 2nd Generation Undermount Clips

Up / Down Adjustment:

Available with 4-way and 6-way clips



Turn wheel to adjust

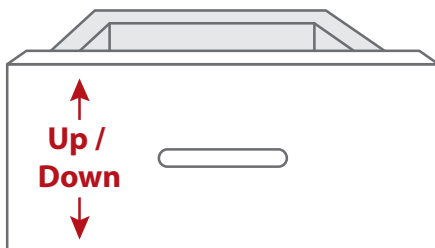

Left / Right Adjustment:

Available with 4-way and 6-way clips

Turn wheel to adjust

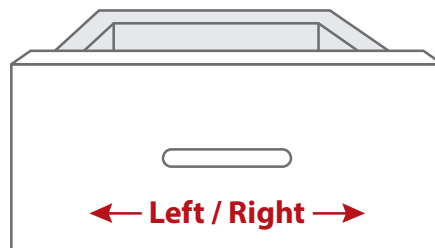
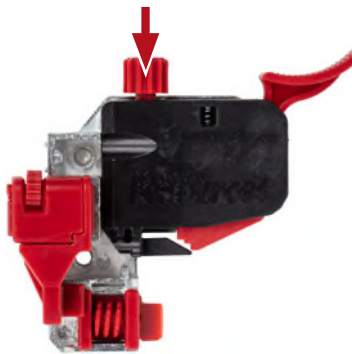

In / Out Adjustment:

Available with 6-way clips

Turn wheel to adjust

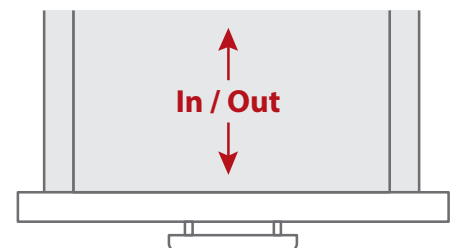
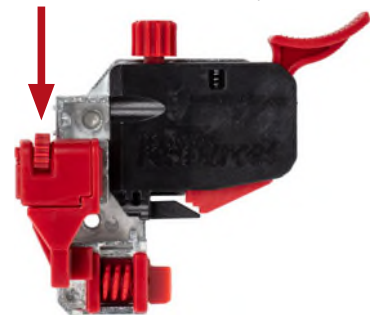

Installation Steps for Frameless Cabinetry

1. Measure and mark cabinet

Measure from the top of the cabinet to the desired drawer location. Draw a level line on the inside of the cabinet where the top of the undermount slide will mount.

2. Position the cabinet member

Use the line and a level to position the cabinet member to the side of the cabinet

- Recommended setback: 4 mm (5/32")
- For inset applications: Inside Cabinet Depth Minimum = Slide Length + Setback + 3 mm (3/16")

3. Secure the slides to the cabinet

Fasten the slides to the cabinet using the fixed screw hole locations and 3 or more #6 x 5/8" screws for both slides ensuring that both cabinet members are level and parallel

4. Install the drawer box

- Set the drawer box inside the cabinet
- Ensure that the slides are resting within the notch at the drawer box
- Press the drawer in toward the rear of the cabinet until both side slides marry with each clip producing an audible click sound ensuring the drawer is locked in place
- Ensure the rear hooks are embedded within the rear hole of both sides of the drawer box

See how to adjust 2nd Generation clips on p. 5

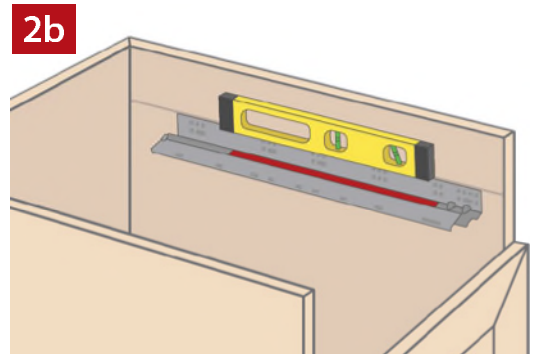
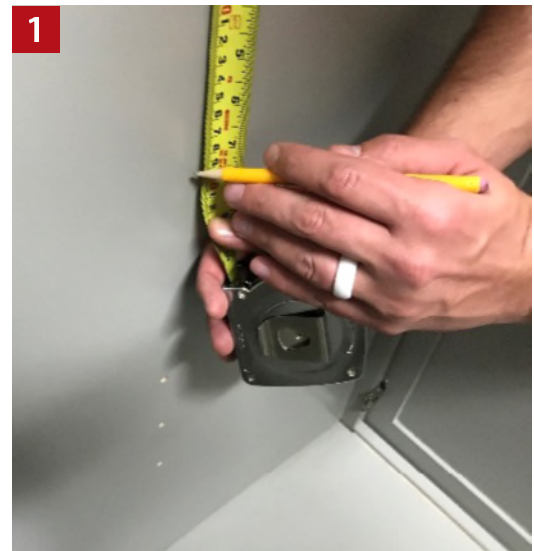
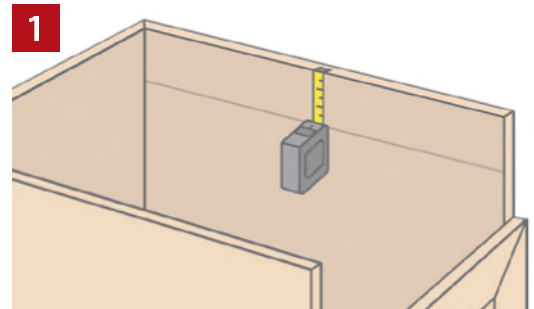

How to Remove a Drawer Box

1. Open and release the drawer box

- Pull the drawer out to the open position and locate the release clip levers on both sides
- Press both levers in to unlock the drawer box then lift the box out of the cabinet

