

- NOTES:
 1. PRODUCT DESIGNED FOR 3/4" WALL FRAMELESS CABINET.
 2. UPPER TRAY EQUIPPED WITH 250MM BALL BEARING FULL EXTENSION SLIDES.

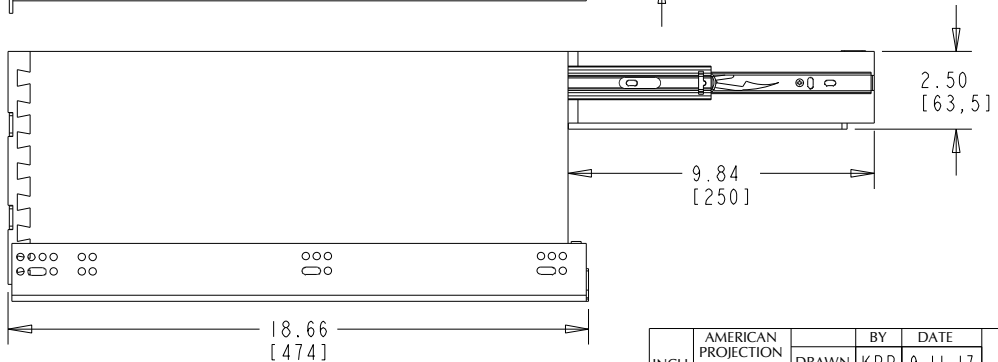
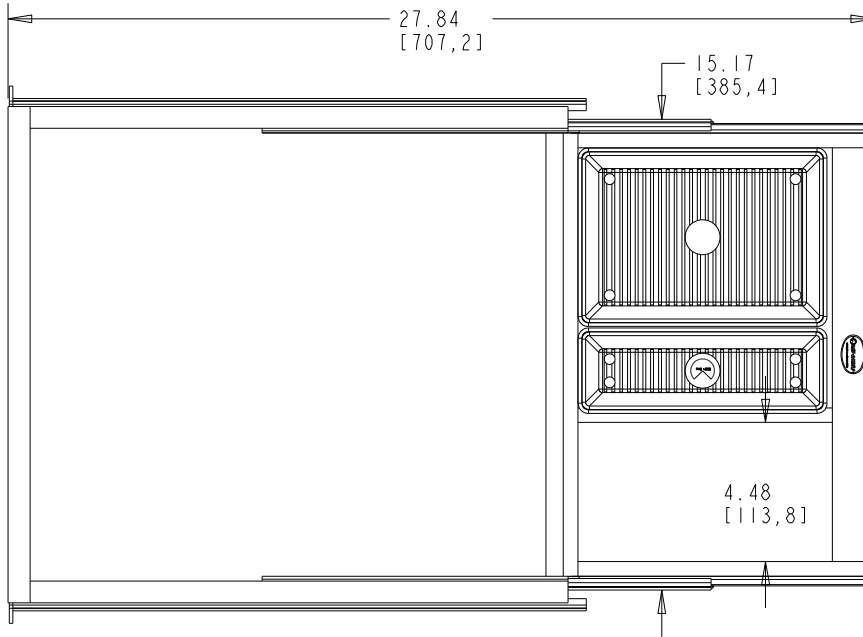
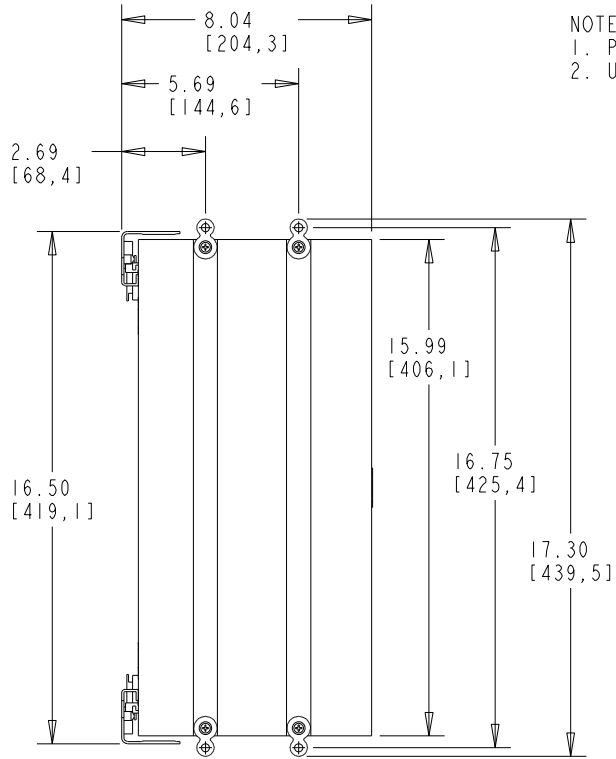

REV.	DATE	BY	DESCRIPTION OF CHANGE

INCH [MM]	AMERICAN PROJECTION	DRAWN	BY	DATE	REV-A-SHELF, INC.
			KRR	9-11-17	
					SIZE B
					DRAWING NO. 4VDOHT-419FLSC-1
					SCALE 0.250
					MATERIAL FINISH
					PART NO. 4VDOHT-419FLSC-1
					SHEET OF 1 2

CUSTOMER DRAWING

This drawing is the property of Rev-A-Shelf (RAS) and is disclosed in confidence to the extent its subject matter is original to RAS. Any vendor receiving this drawing from RAS shall hold and use this drawing for the sole benefit of RAS and shall not disclose it to, or use or reproduce it for any third party, or perform any act adverse to the interest of RAS with respect to this drawing without the express written permission of RAS. Vendors shall not revise any physical, dimensional or performance characteristic unless authorized by Rev-A-Shelf Engineering.

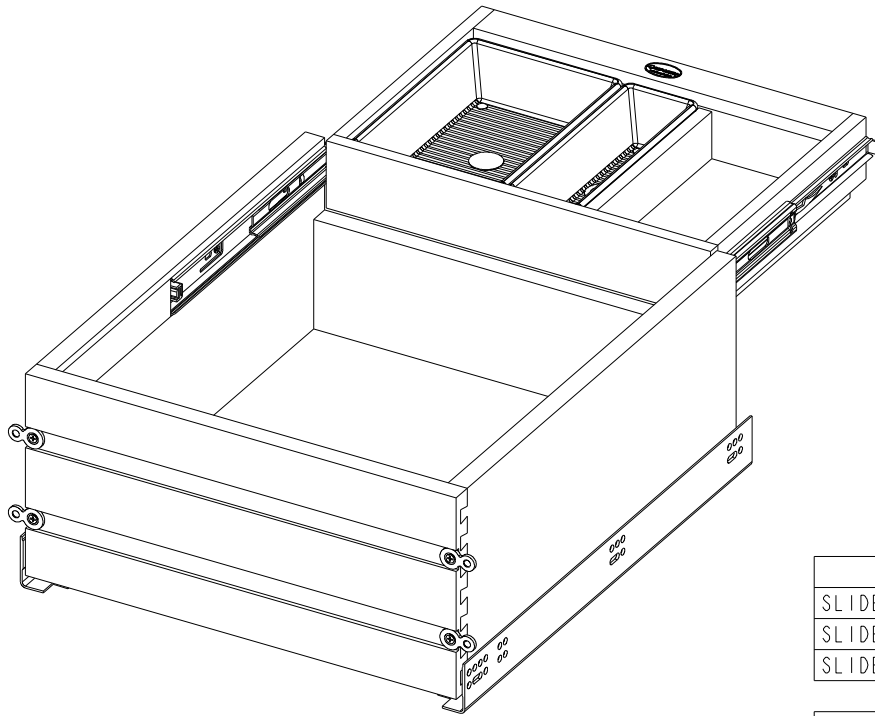

PART DIMENSIONS		
	MIN	MAX
WIDTH	16.50	
DEPTH	18.66	27.84
HEIGHT	8.04	
WEIGHT		
DIAMETER		
RADIUS		
CONTAINER CAPACITY		
CONTAINER UOM		

MIN CABINET OPENING				
	FACE FRAME	FRAMELESS	INSET FACE FRAME	INSET FRAMELESS
WIDTH	16.50	16.50	16.50	16.50
DEPTH	18.75	18.75	19.50	19.50
HEIGHT	8.25	8.25	8.25	8.25

TOP DRAWER SLIDE SPECIFICATIONS				
SLIDE TYPE	BALL BEARING	SLIDE EXTENSION	FULL	MAX WEIGHT RATING
SLIDE CLOSING	NORMAL	SLIDE LENGTH	9.84 [250 MM]	
SLIDE MOUNTING	SIDE	SLIDE FINISH	ZINC	75LB

BOTTOM SLIDE SPECIFICATIONS				
SLIDE TYPE	BLUM BLUMOTION	SLIDE EXTENSION	FULL	MAX WEIGHT RATING
SLIDE CLOSING	SOFT	SLIDE LENGTH	18.00 [457 MM]	
SLIDE MOUNTING	SIDE	SLIDE FINISH	ZINC	100LB

CUSTOMER DRAWING

This drawing is the property of Rev-A-Shelf (RAS) and is disclosed in confidence to the extent its subject matter is original to RAS. Any vendor receiving this drawing from RAS shall hold and use this drawing for the sole benefit of RAS and shall not disclose it to, or use or reproduce it for any third party, or perform any act adverse to the interest of RAS with respect to this drawing without the express written permission of RAS. Vendors shall not revise any physical, dimensional or performance characteristic unless authorized by Rev-A-Shelf Engineering.

REV.	DATE	BY	DESCRIPTION OF CHANGE

INCH [MM]	AMERICAN PROJECTION	DRAWN	BY	DATE	SCALE
			KRR	9-11-17	
			MATERIAL	DRAWING NO.	SCALE
			FINISH	4VDOHT-419FLSC-1	0.250
				PART NO.	SHEET OF
				4VDOHT-419FLSC-1	2 2

TOLERANCES
 MAT. DEC.
 (WOOD) .XX ±.03 [.8mm]
 (OTHER) .XX ±.02 [1.5mm]
 (ALL) .XXX ±.005 [1.3 mm]
 FRACTIONS ±1/32 [.8 mm]

ANGLES
 ±1/2°

REV-A-SHELF, INC.

SIZE B FRAMELESS 18" VANITY TIERED DRAWER