

NOTES:  
1. RECOMMENDED SCREW SIZE INTO DOOR #6X 1/2"  
(PROVIDED BY RAS) QTY 4

CUSTOMER DRAWING

This drawing is the property of Rev-A-Shelf (RAS) and is disclosed in confidence to the extent its subject matter is original to RAS. Any vendor receiving this drawing from RAS shall hold and use this drawing for the sole benefit of RAS and shall not disclose it to, or use or reproduce it for any third party, or perform any act adverse to the interest of RAS with respect to this drawing without the express written permission of RAS. Vendors shall not revise any physical, dimensional or performance characteristic unless authorized by Rev-A-Shelf Engineering.

REV.	DATE	BY	DESCRIPTION OF CHANGE
H	7-8-09	KRR	ECN09-073
G	6-2-09	KRR	ECN09-065
F	12/5/07	PFC	ECN07-098
E	11/28/07	PFC	ECN07-096

AMERICAN PROJECTION		BY	DATE	REV-A-SHELF, INC.	
INCH [MM]	PROJECTION	HLF	10/19/07	SIZE	448BC-08
				<b>B</b>	PULL-OUT BASE ORGANIZER
TOLERANCES		MATERIAL		DRAWING NO.	448BC-08-CUSTOMER
DECIMALS .XX ±.02 [.5mm]		FINISH		PART NO.	448BC-08
FRACTIONS .XXX ±.005 [.13 mm]				SCALE	0.210
ANGLES ±1/2°				SHEET	1 OF 2

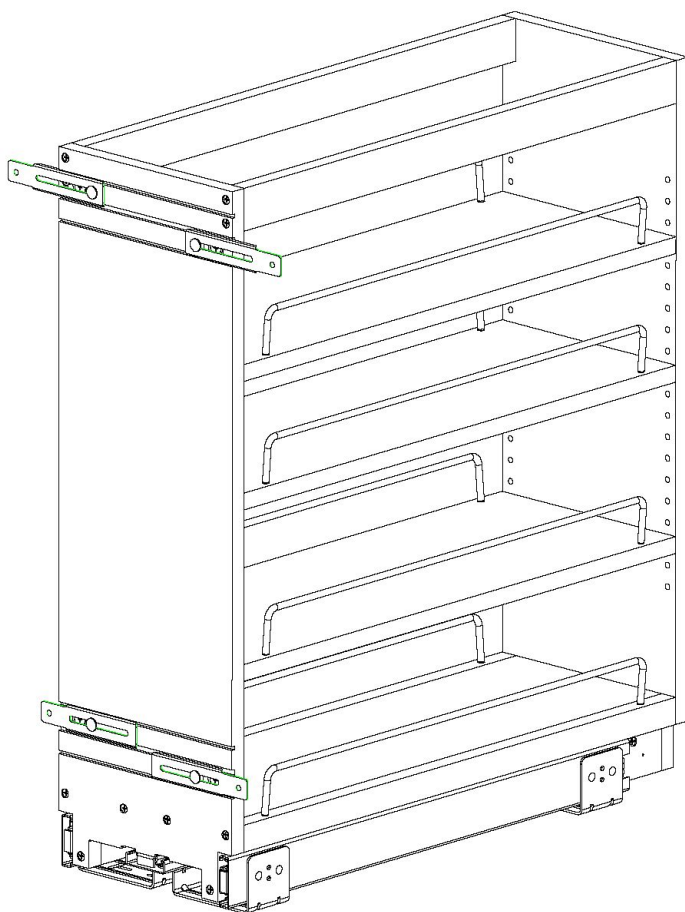

MIN CABINET OPENING	
WIDTH	8.50
DEPTH	22.62
HEIGHT	25.62

PRODUCT MAX WEIGHT RATING
BMHA STANDARD

SLIDE SPECIFICATIONS				
SLIDE TYPE	BALL BEARING	SLIDE EXTENSION	FULL	MAX WEIGHT RATING 100 LB
SLIDE CLOSING	N/A	SLIDE LENGTH	500MM	
SLIDE MOUNTING	N/A	SLIDE FINISH	ZINC	

CUSTOMER DRAWING

This drawing is the property of Rev-A-Shelf (RAS) and is disclosed in confidence to the extent its subject matter is original to RAS. Any vendor receiving this drawing from RAS shall hold and use this drawing for the sole benefit of RAS and shall not disclose it to, or use or reproduce it for any third party, or perform any act adverse to the interest of RAS with respect to this drawing without the express written permission of RAS. Vendors shall not revise any physical, dimensional or performance characteristic unless authorized by Rev-A-Shelf Engineering.

H	7-8-09	KRR	ECN09-073	AMERICAN PROJECTION INCH [MM] 	BY	DATE	REV-A-SHELF® INC. SIZE B 448BC-08 PULL-OUT BASE ORGANIZER DRAWING NO. 448BC-08-CUSTOMER PART NO. 448BC-08	SCALE	0.250	
G	6-2-09	KRR	ECN09-065		DRAWN	HLF		10/19/07	SHEET	2
F	12/5/07	PFC	ECN07-098		TOLERANCES DECIMALS .XX ±.02 [.5mm] .XXX ±.005 [.13 mm] FRACTIONS ±1/32 [.8 mm]			MATERIAL		OF
E	11/28/07	PFC	ECN07-096	ANGLES ±1/2°		FINISH				
REV.	DATE	BY	DESCRIPTION OF CHANGE							