

NOTES:  
RECOMMENDED SCREW SIZE INTO  
DOOR #6 X 1/2" (PROVIDED BY RAS) QTY 4  
CUSTOMER DRAWING

This drawing is the property of Rev-A-Shelf (RAS) and is disclosed in confidence to the extent its subject matter is original to RAS. Any vendor receiving this drawing from RAS shall hold and use this drawing for the sole benefit of RAS and shall not disclose it to, or use or reproduce it for any third party, or perform any act adverse to the interest of RAS with respect to this drawing without the express written permission of RAS. Vendor shall not revise any physical, dimensional or performance characteristic unless authorized by Rev-A-Shelf Engineering.

REV.	DATE	BY	DESCRIPTION OF CHANGE
A	6/24/08	BT	ECN08-049

AMERICAN PROJECTION	BY	DATE	REV-A-SHELF, Inc.	
INCH [MM]	DRAWN	PFC	6/23/08	448BC14
				SIZE B
TOLERANCES			MATERIAL	DRAWING NO.
DECIMALS	ANGLES	FINISH	448BC14-CUSTOMER	SCALE
.XX ±.02 [.5mm]	±1/2°		PART NO.	3:16
.XXX ±.005 [.13 mm]			448BC14	SHEET 1 OF 2
FRACTIONS ±1/32 [.8 mm]				

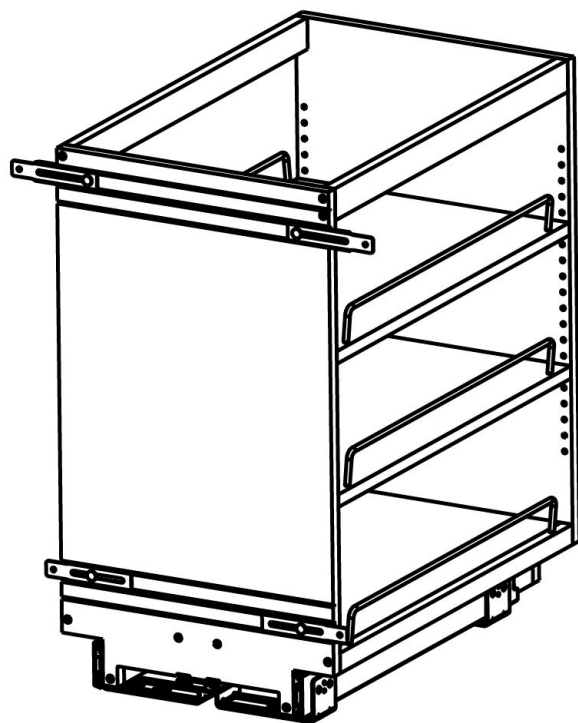

PART DIMENSIONS		
	MIN	MAX
WIDTH	14.00"	
DEPTH	22.46"	
HEIGHT	25.50"	
WEIGHT	47.5 LBS	
DIAMETER		
RADIUS		
CONTAINER CAPACITY		
CONTAINER UOM		

MIN CABINET OPENING	
WIDTH	14.50"
DEPTH	22.62"
HEIGHT	25.62"

PRODUCT MAX WEIGHT RATING

SLIDE SPECIFICATIONS				
SLIDE TYPE	BALL BEARING	SLIDE EXTENSION	FULL EXTENSION	MAX WEIGHT RATING
SLIDE CLOSING	N/A	SLIDE LENGTH	500MM	
SLIDE MOUNTING	N/A	SLIDE FINISH	ZINC	
				150LB

CUSTOMER DRAWING

This drawing is the property of Rev-A-Shelf (RAS) and is disclosed in confidence to the extent its subject matter is original to RAS. Any vendor receiving this drawing from RAS shall hold and use this drawing for the sole benefit of RAS and shall not disclose it to, or use or reproduce it for any third party, or perform any act adverse to the interest of RAS with respect to this drawing without the express written permission of RAS. Vendors shall not revise any physical, dimensional or performance characteristic unless authorized by Rev-A-Shelf Engineering.

REV.	DATE	BY	DESCRIPTION OF CHANGE
A	6/24/08	BT	ECN08-049

INCH [MM]	AMERICAN PROJECTION	BY	DATE	
		DRAWN	PFC 6/23/08	
<b>TOLERANCES</b> DECIMALS .XX ±.02 [.5mm] .XXX ±.005 [.13 mm] FRACTIONS ±1/32 [.8 mm]				SIZE <b>B</b>
ANGLES ±1/2°		MATERIAL	DRAWING NO.	SCALE
FINISH		448BC14-CUSTOMER	448BC14	3:16
		PART NO.	448BC14	SHEET 2 OF 2