

**StarTec®**

- For flush interior wood doors - 3D Adjustable
- Suitable for left or right hand installation

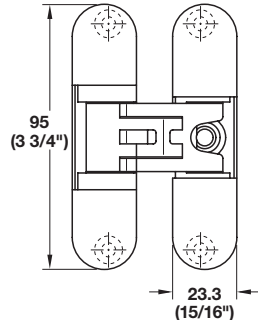

**Mounting**

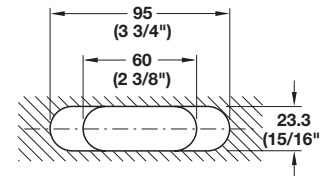
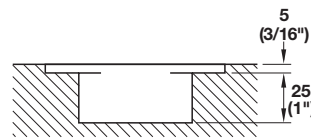
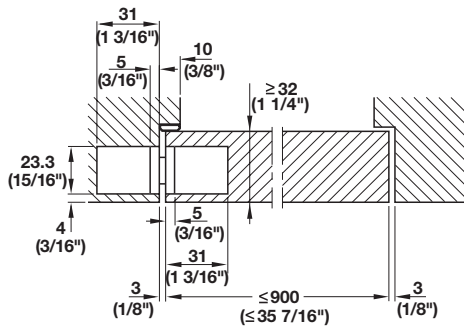

**H2**

- Door weight:  $\leq 45$  kg (99 lbs.) with 2 hinges  
 $\leq 60$  kg (132 lbs.) with 3 hinges
- Opening angle:  $\leq 180^\circ$
- Door width:  $\leq 900$  mm ( $\leq 35$  7/16")
- Door height:  $\leq 2000$  mm ( $\leq 78$  3/4")  
 $\geq 2100$  mm ( $\geq 82$  11/16") use 4 hinges
- Door thickness:  $\geq 32$  mm (1 1/4")
- Adjustability: Continuously three dimensional adjustable  
 Height  $\pm 2.5$  mm (3/32"),  
 Lateral  $+3$  mm/ $-2$  mm ( $+1/8$ "/ $-1/16$ "")  
 On contact  $\pm 1$  mm (1/32")

Material: Zinc Die-cast

Finish	Item No.
satin chrome	927.91.544
satin nickel	927.91.546
gold polished	927.91.548

**Note**

When using the receiving element the milling dimensions may change.

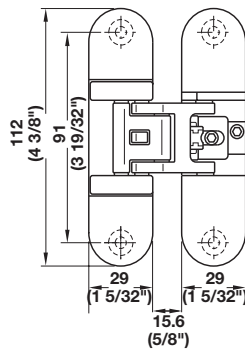
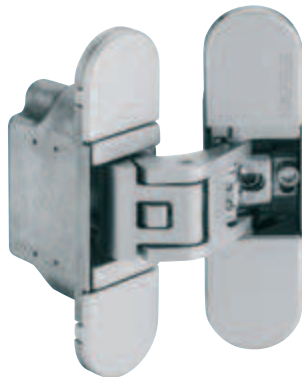

**Mounting**

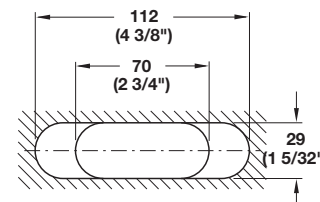
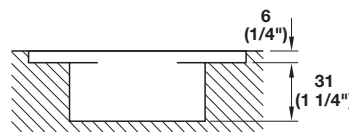
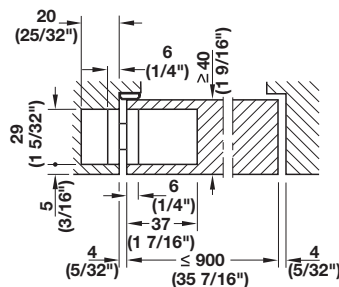

**H7**

- Door weight:  $\leq 50$  kg (110 lbs.) with 2 hinges  
 $\leq 70$  kg (154 lbs.) with 3 hinges
- Opening angle:  $\leq 180^\circ$
- Door width:  $\leq 900$  mm ( $\leq 35$  7/16")
- Door height:  $\leq 2700$  mm ( $\leq 8'$  10 5/16")  
 $\geq 2400$  mm ( $\geq 7'$  10 1/2") use 4 hinges
- Door thickness:  $\geq 40$  mm (1 9/16")
- Adjustability: Continuously three dimensional adjustable  
 Height  $\pm 3.0$  mm (1/8"),  
 Lateral  $+3$  mm/ $-2$  mm ( $+1/8$ "/ $-1/16$ "")  
 On contact  $\pm 1$  mm (1/32")

Material: Zinc Die-cast

Finish	Item No.
satin chrome	927.91.554
satin nickel	927.91.556
gold polished	927.91.558

**Note**

When using the receiving element the milling dimensions may change.

Dimensional data not binding. We reserve the right to alter specifications without notice.

Dimensions in mm  
 Inches are approximate