

NOTES:

1. PRODUCT DESIGNED FOR 1.5" FACE FRAME.
2. Ø.25" HOLES IN BACK DESIGNED FOR BLUM BLUMOTION 563F5330B UNDERMOUNT SLIDES OR GRASS ELITE 7523-19/550/533 UNDERMOUNT SLIDES.
3. UPPER TRAY EQUIPPED WITH 450MM BALL BEARING FULL EXTENSION SLIDES.

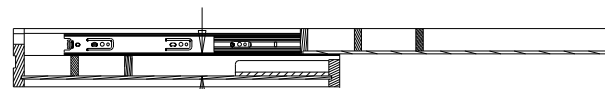
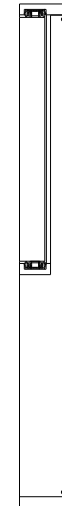
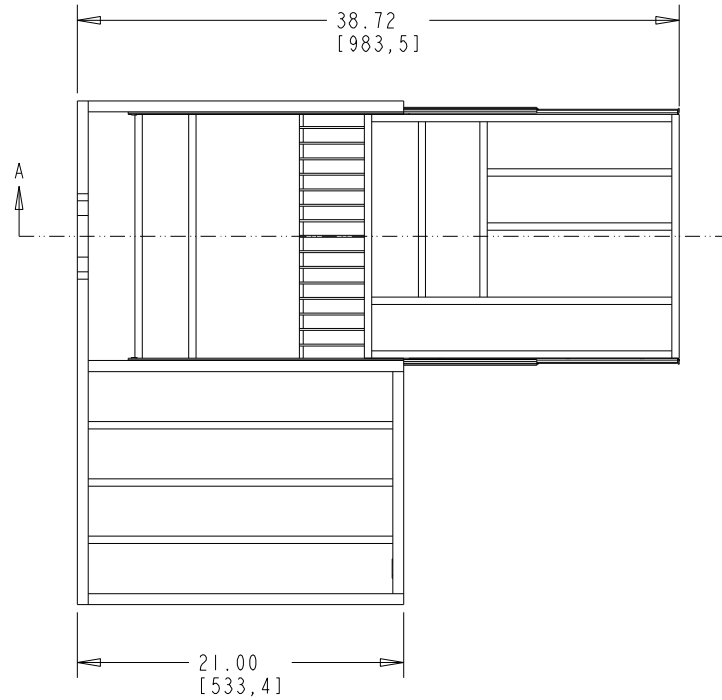
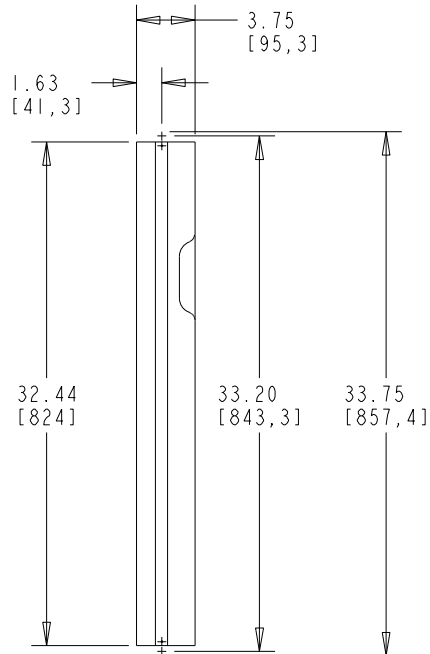

SECTION A-A

1.43
[36, 3]
BOTTOM OF TRAY
TO FLOOR

CUSTOMER DRAWING

This drawing is the property of Rev-A-Shelf (RAS) and is disclosed in confidence to the extent its subject matter is original to RAS. Any vendor receiving this drawing from RAS shall hold and use this drawing for the sole benefit of RAS and shall not disclose it to, or use or reproduce it for any third party, or perform any act adverse to the interest of RAS with respect to this drawing without the express written permission of RAS. Vendors shall not revise any physical, dimensional or performance characteristic unless authorized by Rev-A-Shelf Engineering.

REV.	DATE	BY	DESCRIPTION OF CHANGE

INCH [MM] 	AMERICAN PROJECTION	DRAWN	BY	DATE	REV-A-SHELF, INC. SIZE B
		KRR	KRR	10-7-15	
MAT. DEC. (WOOD) .XX ±.03 [.8mm] (OTHER) .XX ±.02 [1.5mm] (ALL) .XXX ±.005 [1.3 mm] FRACTIONS ±1/32 [1.8 mm]		TOLERANCES ANGLES ±1/2°		MATERIAL	DRAWING NO.
		FINISH			SCALE
				PART NO.	SHEET OF
				4WTCD-36-1	0.125
				4WTCD-36-1	1 2

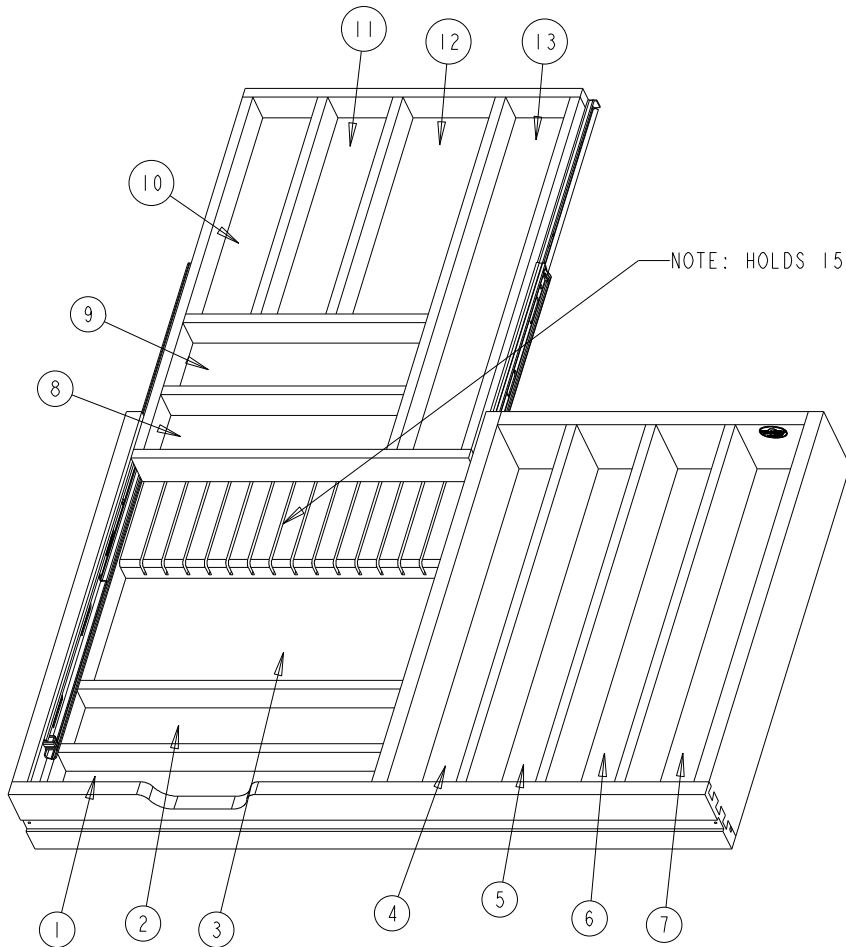

NOTE: HOLDS 15 STEAK KNIVES

COMPARTMENT DIMENSIONS			
NUMBER	WIDTH	DEPTH	HEIGHT
1	16.00	3.00	1.40
2	16.00	3.00	1.40
3	16.00	12.64	1.40
4	3.22	19.58	3.00
5	3.22	19.58	3.00
6	3.22	19.58	3.00
7	3.22	19.58	3.00
8	11.30	3.00	1.43
9	11.30	3.49	1.43
10	3.03	11.88	1.43
11	3.03	11.88	1.43
12	4.30	11.88	1.43
13	3.00	19.31	1.43

PART DIMENSIONS		
	MIN	MAX
WIDTH	32.44	
DEPTH	21.00	38.72
HEIGHT	3.75	
WEIGHT		
DIAMETER		
RADIUS		
CONTAINER CAPACITY		
CONTAINER UOM		

MIN CABINET OPENING	
WIDTH	33.00
DEPTH	22.25
HEIGHT	4.50

PRODUCT MAX WEIGHT RATING	

TOP DRAWER SLIDE SPECIFICATIONS				
SLIDE TYPE	BALL BEARING	SLIDE EXTENSION	FULL	MAX WEIGHT RATING
SLIDE CLOSING	NORMAL	SLIDE LENGTH	17.72 [450MM]	
SLIDE MOUNTING	SIDE	SLIDE FINISH	ZINC	75LB

CUSTOMER DRAWING

This drawing is the property of Rev-A-Shelf (RAS) and is disclosed in confidence to the extent its subject matter is original to RAS. Any vendor receiving this drawing from RAS shall hold and use this drawing for the sole benefit of RAS and shall not disclose it to, or use or reproduce it for any third party, or perform any act adverse to the interest of RAS with respect to this drawing without the express written permission of RAS. Vendors shall not revise any physical, dimensional or performance characteristic unless authorized by Rev-A-Shelf Engineering.

REV.	DATE	BY	DESCRIPTION OF CHANGE

INCH [MM]	AMERICAN PROJECTION	DRAWN	BY	DATE	SIZE	DRAWING NO.	SCALE
		KRR		10-7-15			
TOLERANCES		MATERIAL		PART NO.		SHEET OF	
MAT. DEC. (WOOD) .XX ±.03 [.8mm] (OTHER) .XX ±.02 [1.5mm] (ALL) .XXX ±.005 [1.3 mm] FRACTIONS ±1/32 [1.8 mm]		FINISH		4WTCD-36-1		2 OF 2	